

MP 84 Series
MP 98 Series
SD 98 Series
SD 108 Series

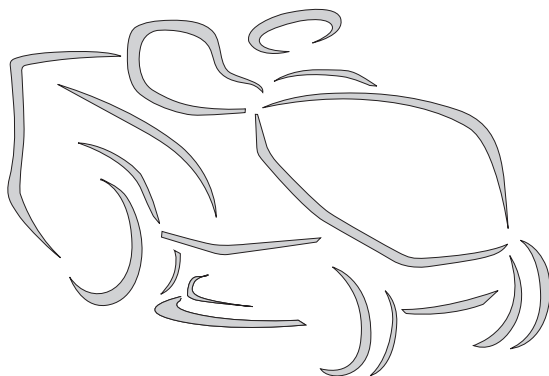

STIGA[®]



IT Tosaerba con conducente a bordo seduto - MANUALE DI ISTRUZIONI
ATTENZIONE: prima di usare la macchina, leggere attentamente il presente libretto.

DE Aufsitzmäher (Rasenmäher mit Fahrersitz mit sitzendem Benutzer)
GEBRAUCHSANWEISUNG

ACHTUNG: vor inbetriebnahme des Geräts die Gebrauchsanleitung aufmerksam lesen.

EN Ride-on lawnmower with seated operator - OPERATOR'S MANUAL
WARNING: read thoroughly the instruction booklet before using the machine.

FR Tondeuse à gazon à conducteur assis - MANUEL D'UTILISATION
ATTENTION: lire attentivement le manuel avant d'utiliser cette machine.

NL Grasmaaier met zittende bediener - GEBRUIKERSHANDLEIDING
LET OP: vooraleer de machine te gebruiken, dient men deze handleiding aandachtig te lezen.

ITALIANO - Istruzioni Originali	IT
БЪЛГАРСКИ - Инструкция за експлоатация	BG
BOSANSKI - Prijevod originalnih uputa	BS
ČESKY - Překlad původního návodu k používání	CS
DANSK - Oversættelse af den originale brugsanvisning	DA
DEUTSCH - Übersetzung der Originalbetriebsanleitung	DE
ΕΛΛΗΝΙΚΑ - Μετάφραση των πρωτοτύπων οδηγιών	EL
ENGLISH - Translation of the original instruction	EN
ESPAÑOL - Traducción del Manual Original	ES
EESTI - Algupärase kasutusjuhendi tõlge	ET
SUOMI - Alkuperäisten ohjeiden käännös	FI
FRANÇAIS - Traduction de la notice originale	FR
HRVATSKI - Prijevod originalnih uputa	HR
MAGYAR - Eredeti használati utasítás fordítása	HU
LIETUVIŠKAI - Originalių instrukcijų vertimas	LT
LATVIEŠU - Instrukciju tulkojums no oriģināl valodas	LV
МАКЕДОНСКИ - Превод на оригиналните упатства	MK
NEDERLANDS - Vertaling van de oorspronkelijke gebruiksaanwijzing	NL
NORSK - Oversettelse av den originale bruksanvisningen	NO
POLSKI - Tłumaczenie instrukcji oryginalnej	PL
PORTUGUÊS - Tradução do manual original	PT
ROMÂN - Traducerea manualului fabricantului	RO
РУССКИЙ - Перевод оригинальных инструкций	RU
SLOVENSKY - Preklad pôvodného návodu na použitie	SK
SLOVENŠČINA - Prevod izvornih navodil	SL
SRPSKI - Prevod originalnih uputstva	SR
SVENSKA - Översättning av bruksanvisning i original	SV
TÜRKÇE - Orijinal Talimatların Tercümesi	TR

1

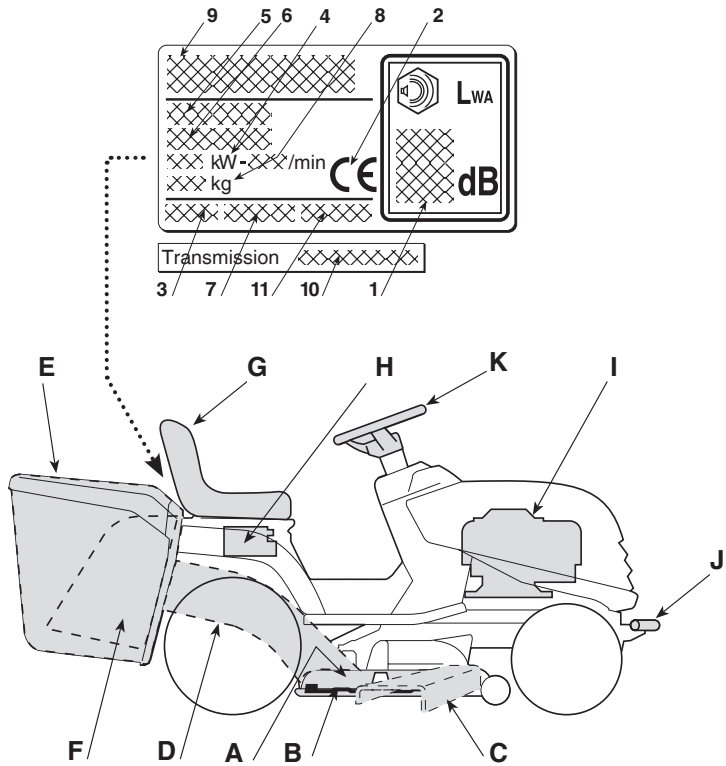

2

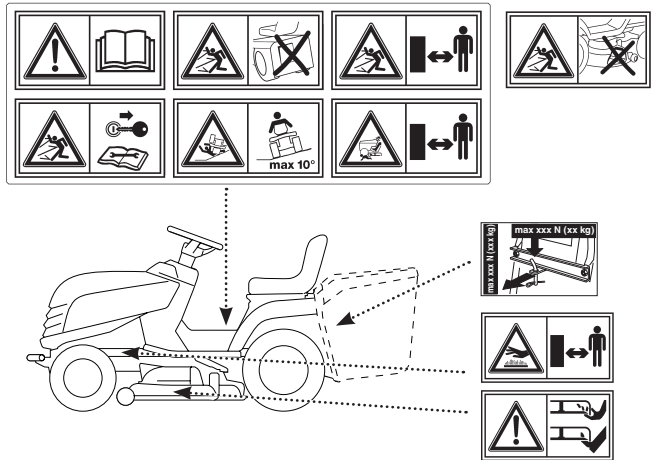

3

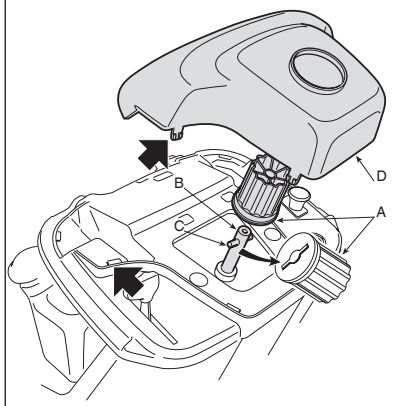

I

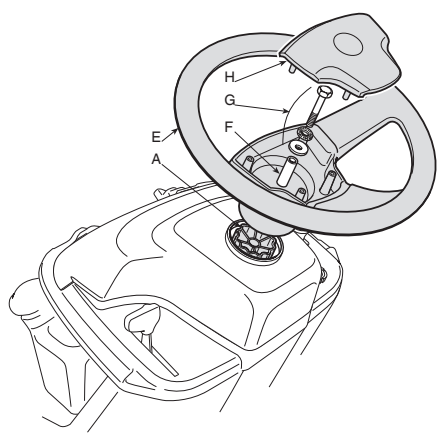

II

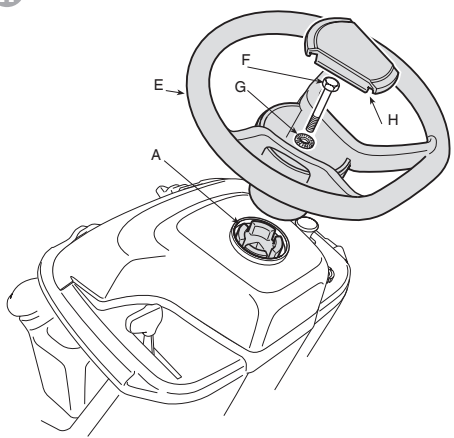
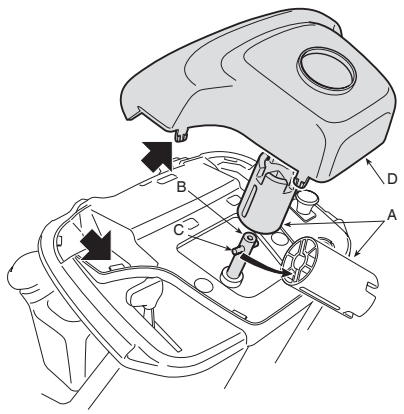

4

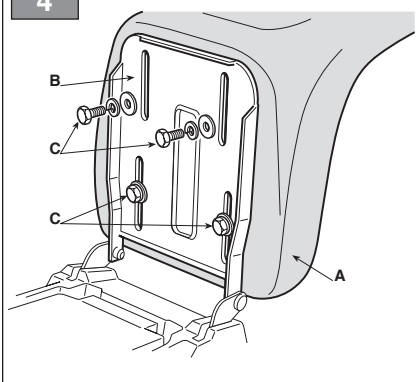

5

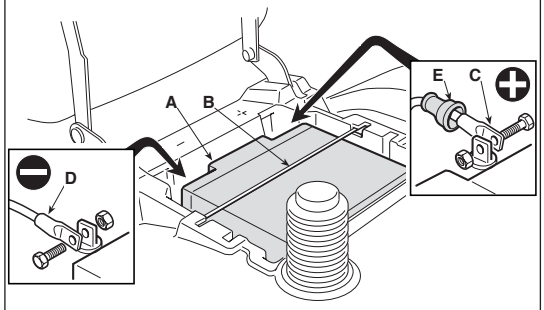

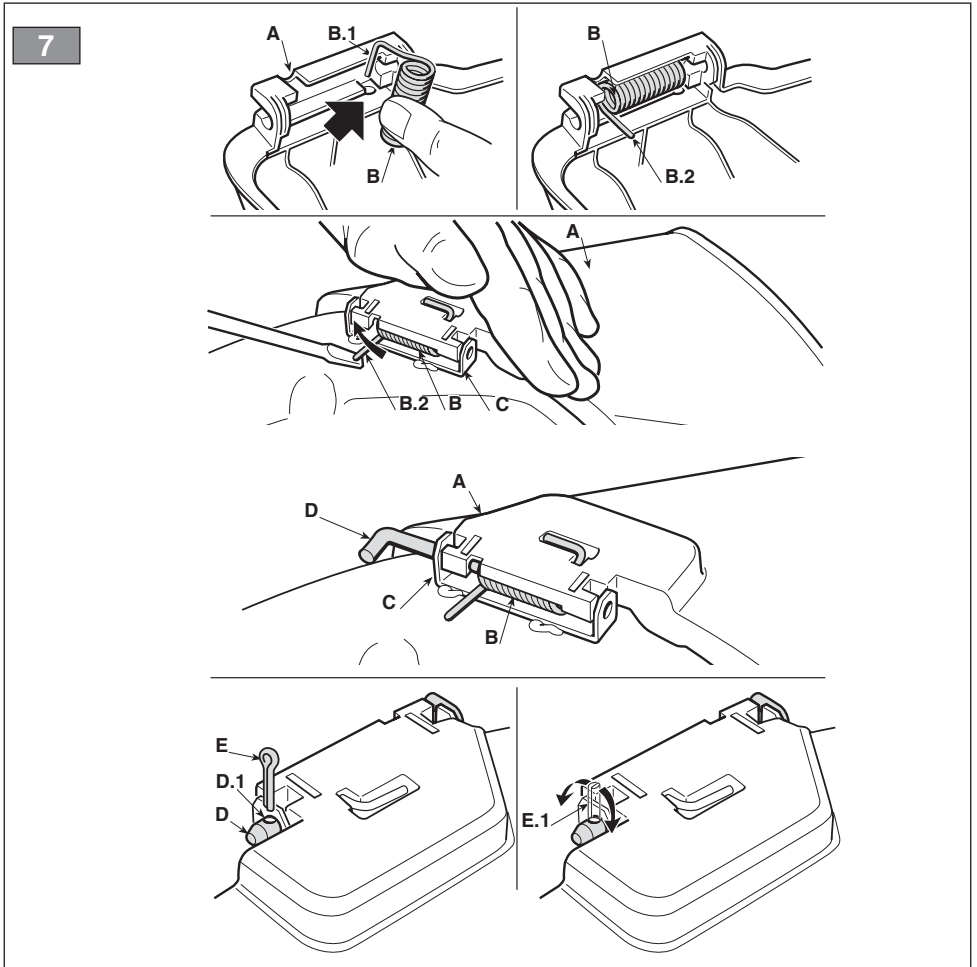
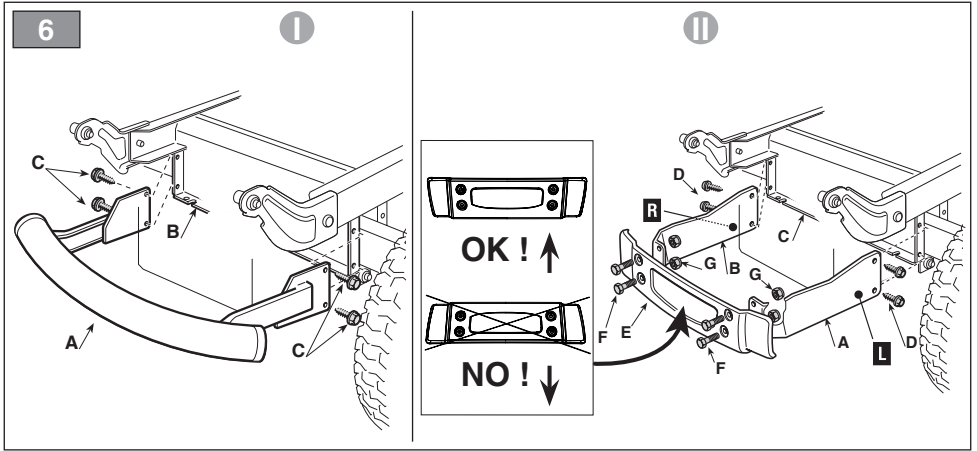

8

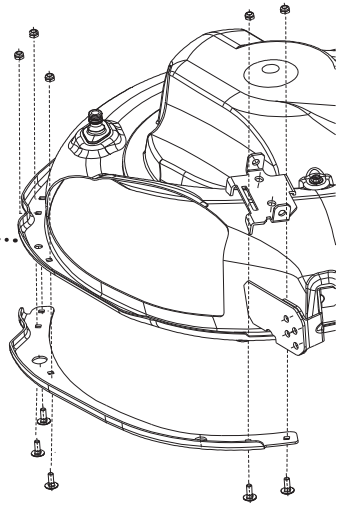
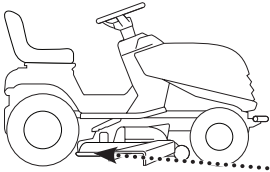

9

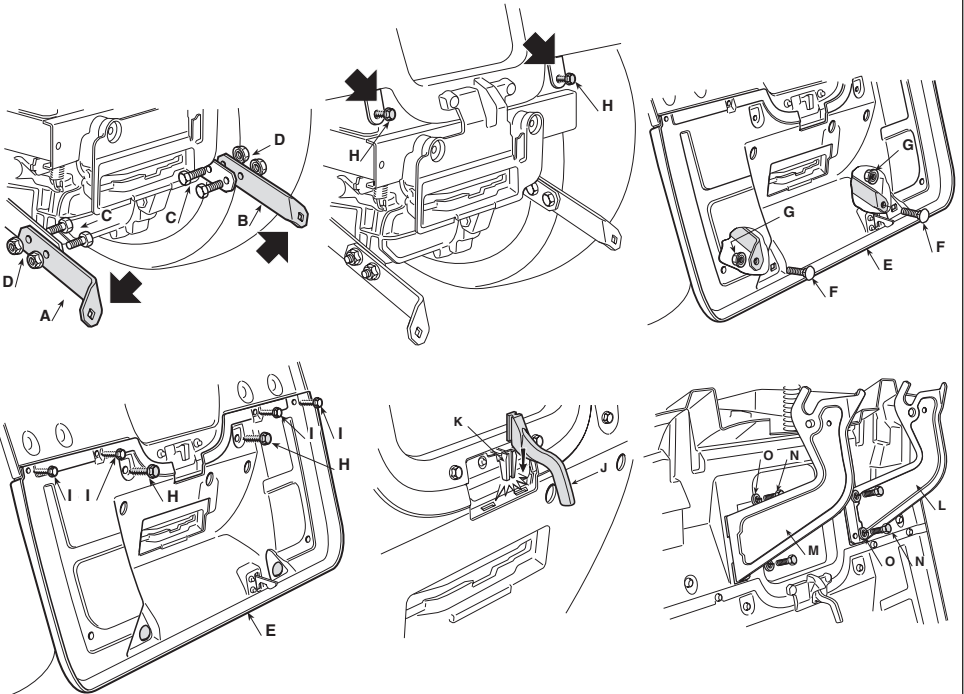
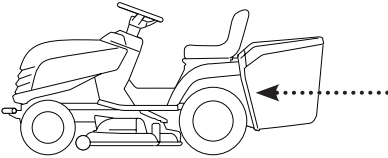

10

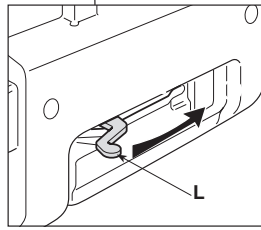
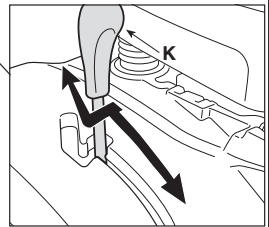
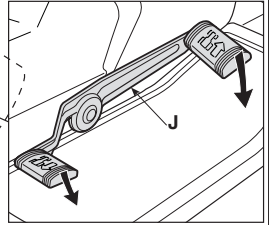
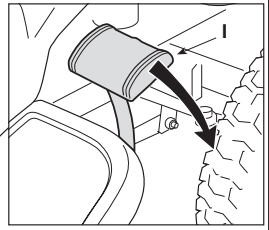
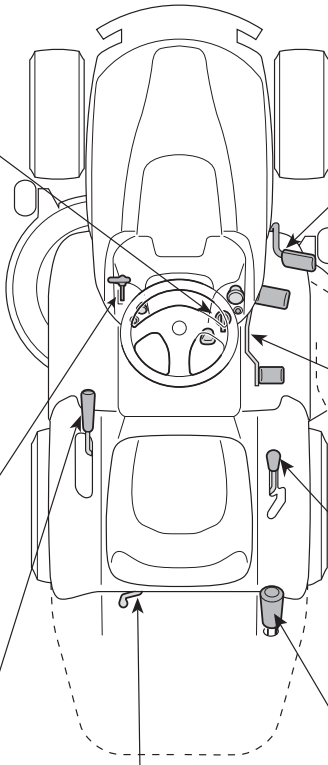
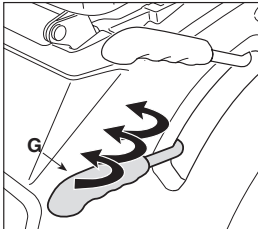
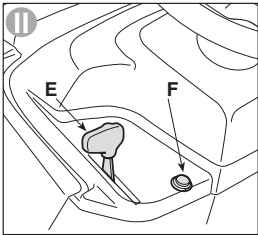
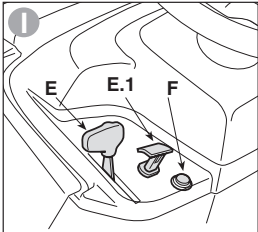
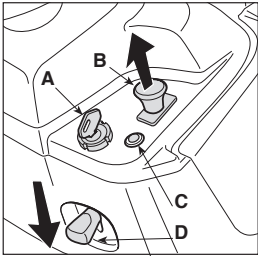

H

11

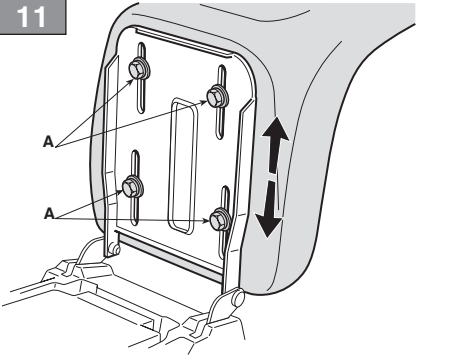

12

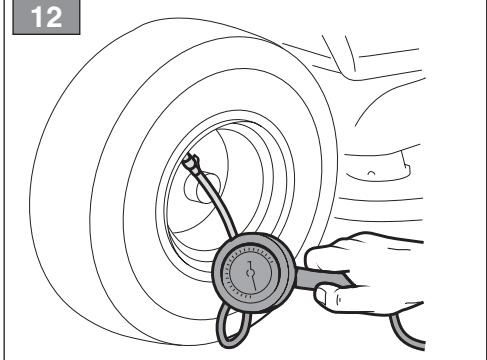

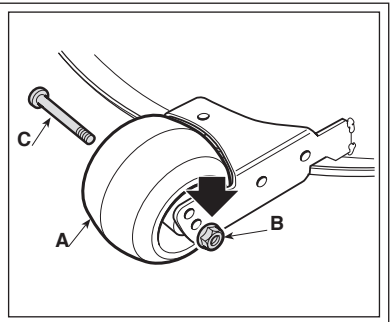
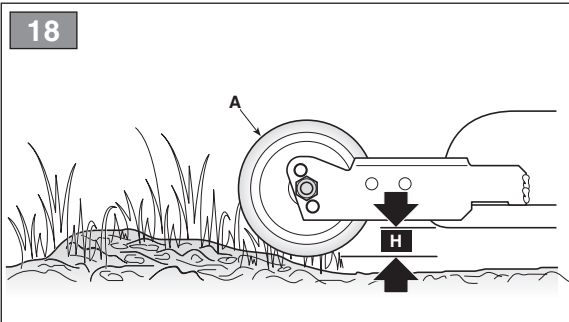
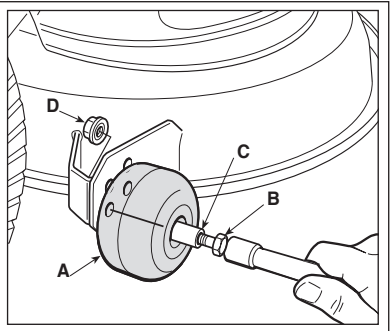
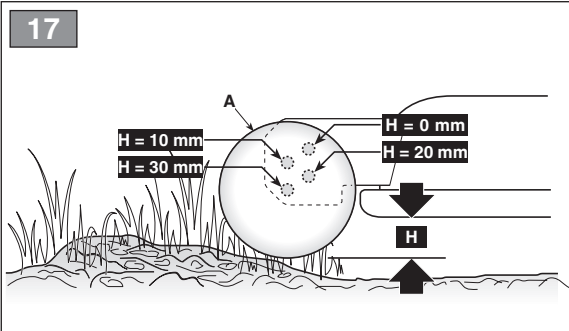
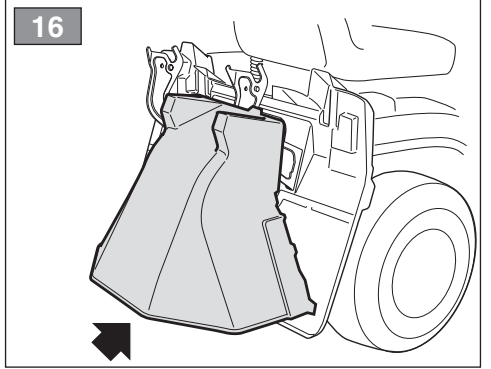
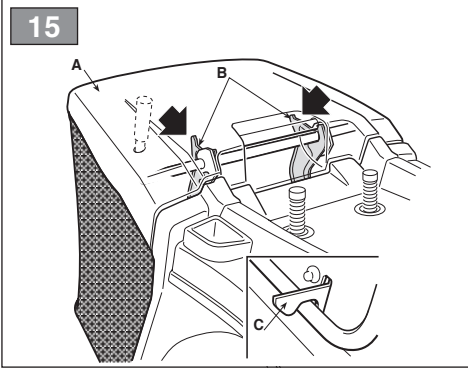
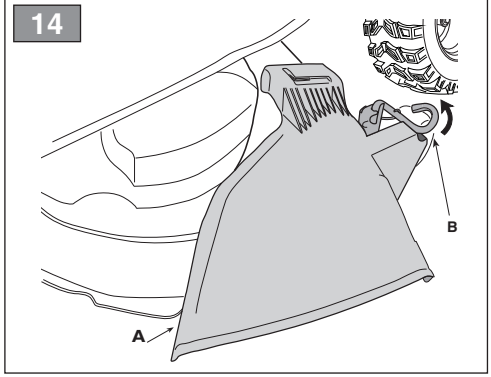
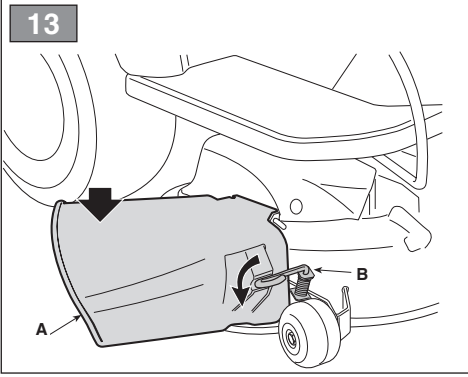

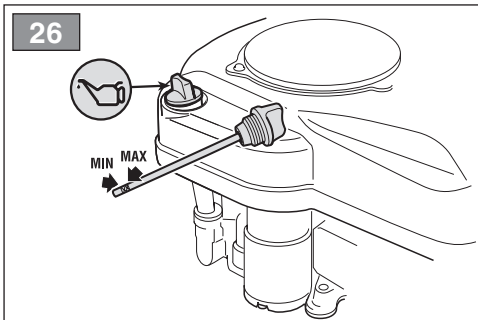
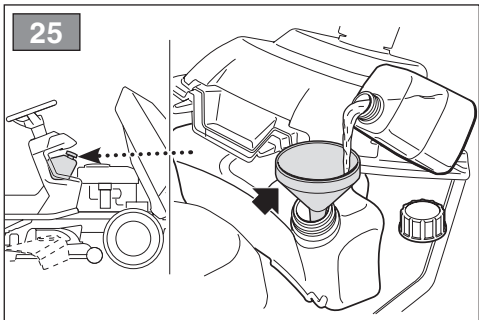
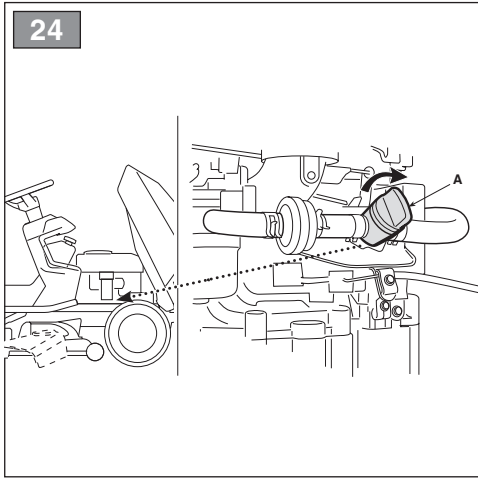
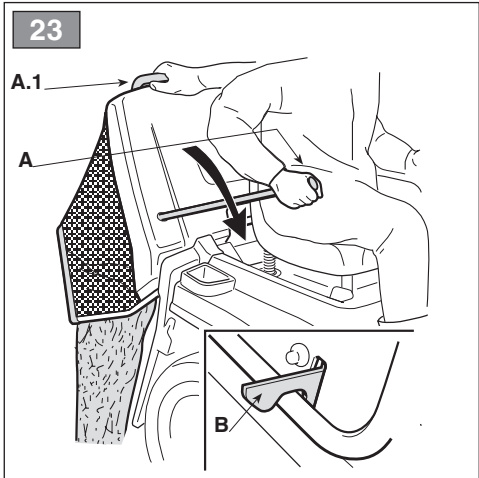
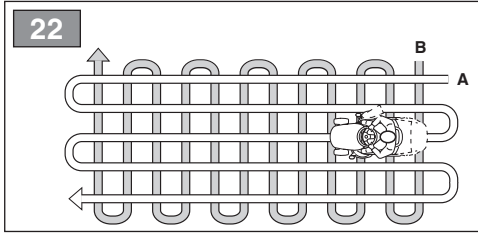
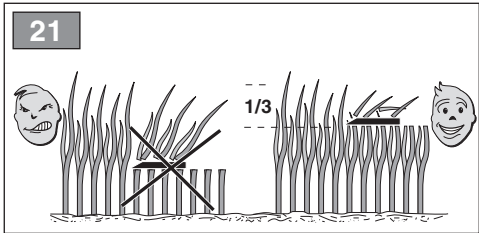
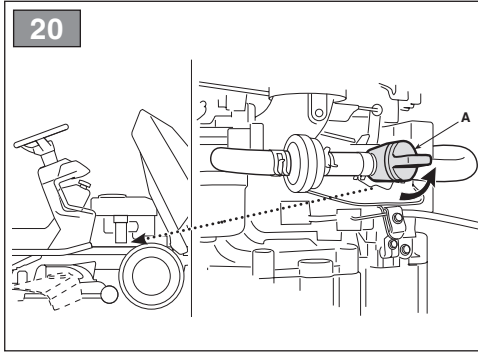
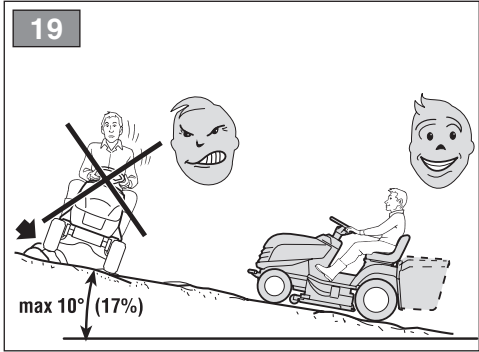

27

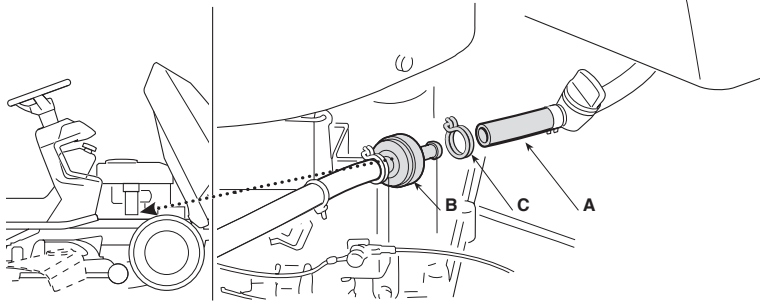

28

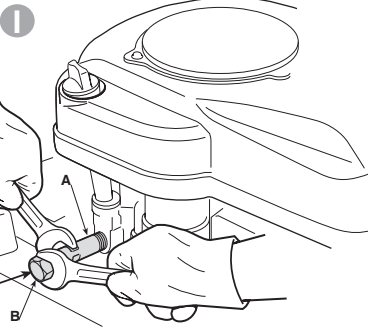

II

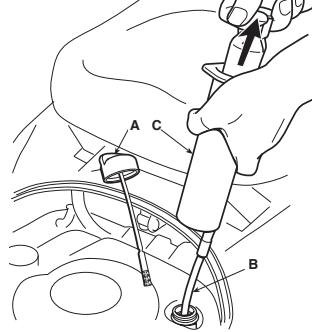

29

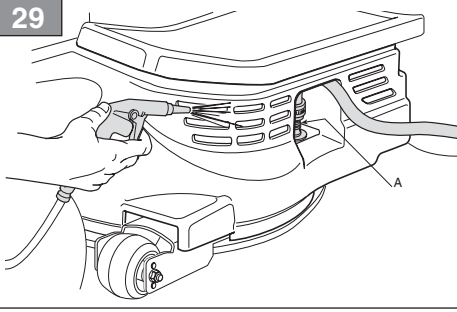

30

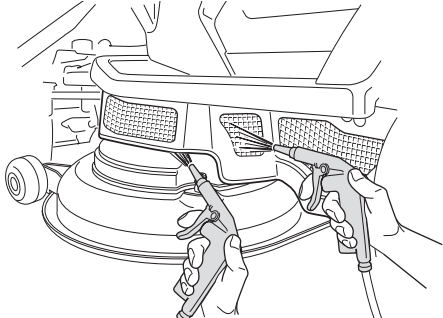
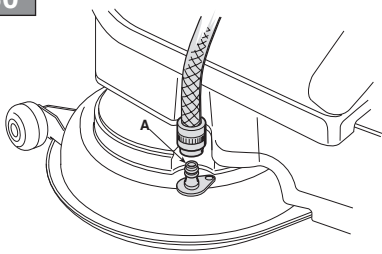

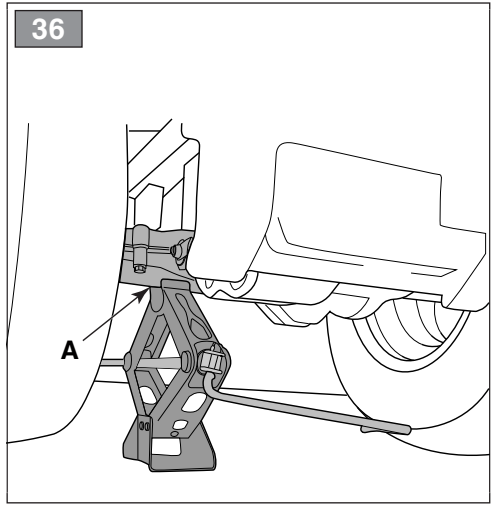
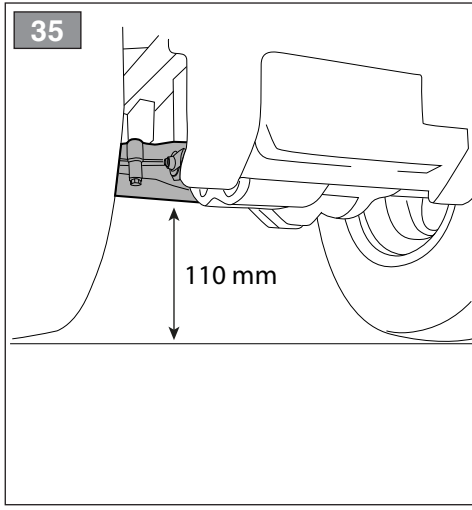
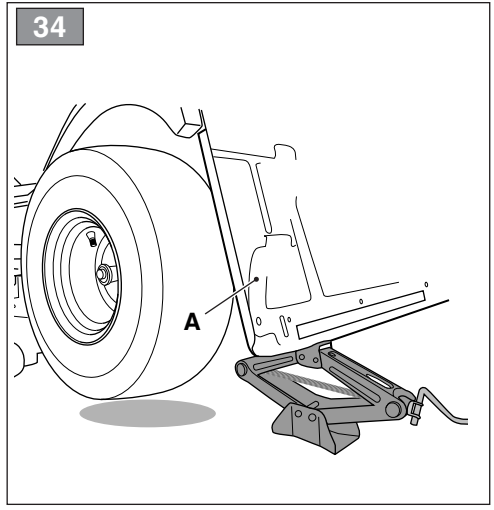
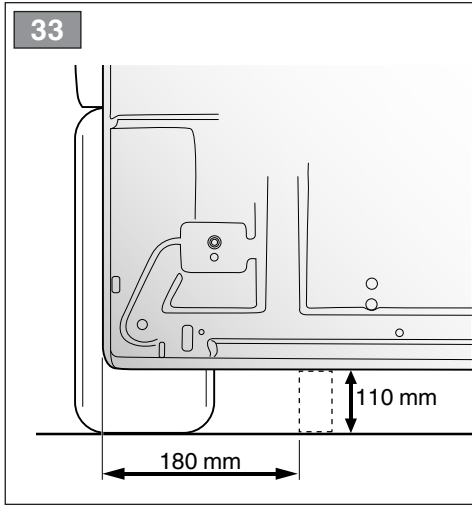
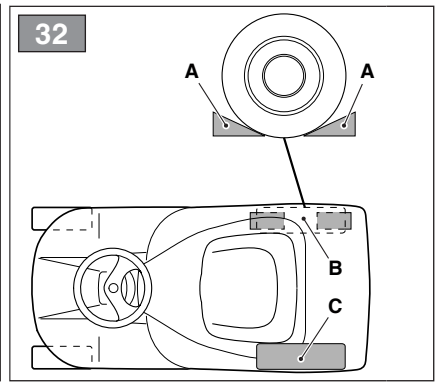
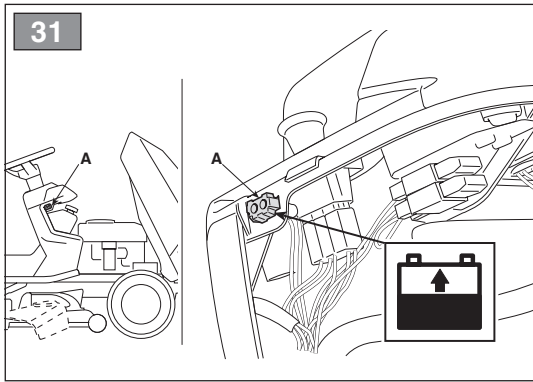

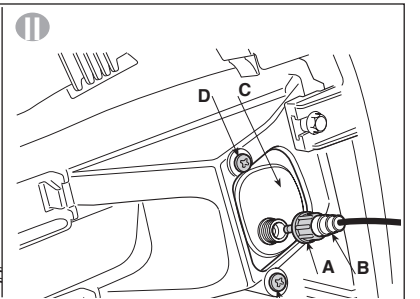
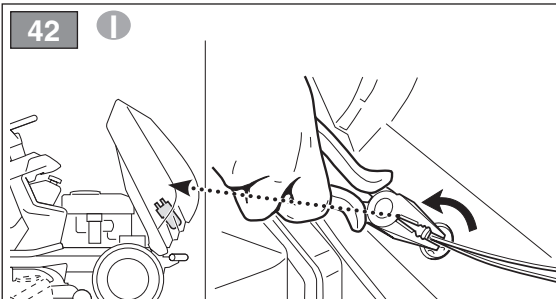
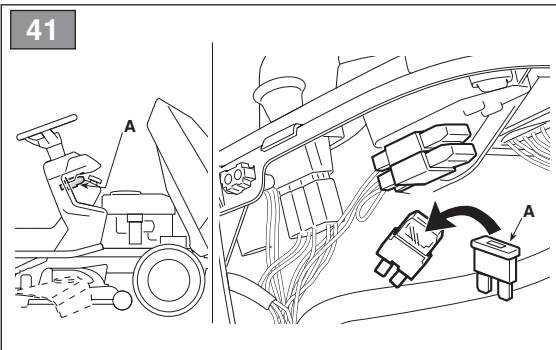
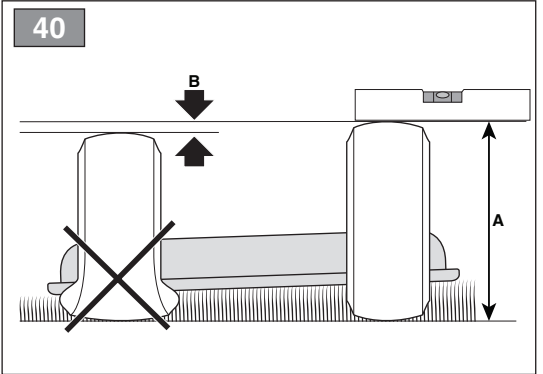
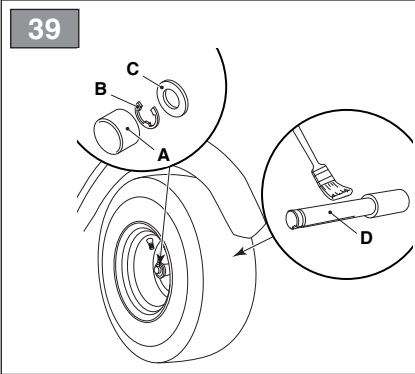
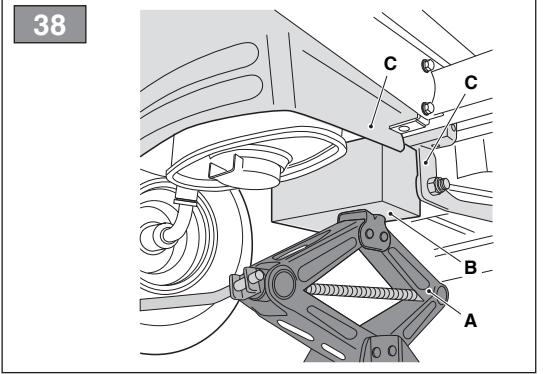
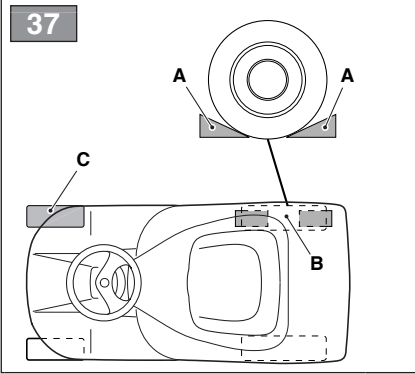

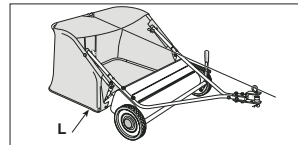
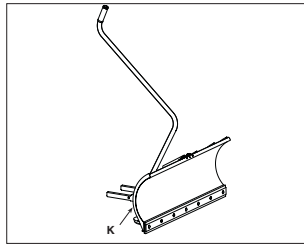
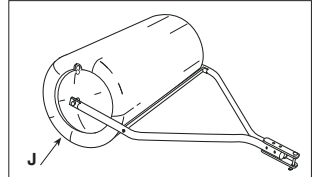
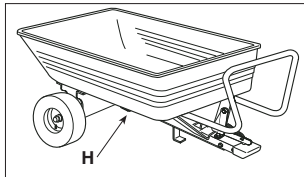
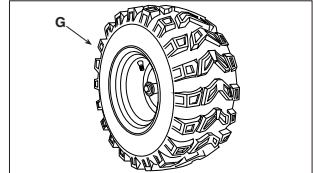
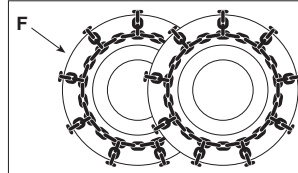
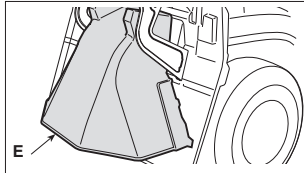
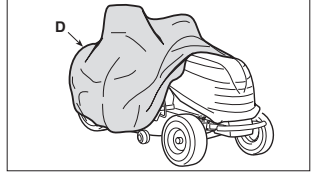
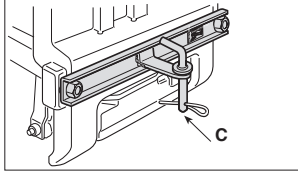
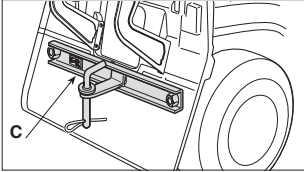
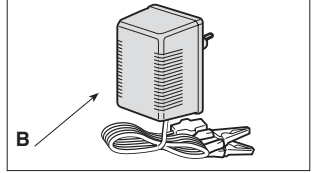
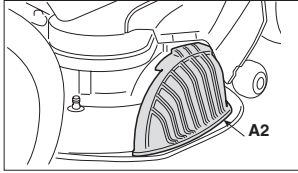
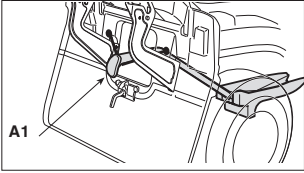







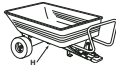

[1]	DATI TECNICI		SD 98 Series	SD 108 Series
[2]	Potenza nominale *	kW	6,4 ÷ 11,5	6,4 ÷ 11,5
[3]	Giri al minuto *	min ⁻¹	2800 ± 100	2800 ± 100
[4]	Impianto elettrico	V	12	12
[5]	Pneumatici anteriori		13 x 5,00-6 (15 x 5,00-6)	13 x 5,00-6 (15 x 5,00-6)
[6]	Pneumatici posteriori		18 x 8,50-8	18 x 8,50-8
[7]	Pressione gonfiaggio anteriore 13 x 5,00-6 15 x 5,00-6	bar bar	1,5 1,0	1,5 1,0
[8]	Pressione gonfiaggio posteriore	bar	1,2	1,2
[9]	Massa *	kg	160 ÷ 171	160 ÷ 171
[10]	Raggio minimo di erba non tagliata	cm	70	65
[11]	Altezza di taglio	cm	3 ÷ 8,5	3 ÷ 8,5
[12]	Larghezza di taglio	cm	98	107
[13]	Capacità del sacco di raccolta	l	-	-
[14]	<i>Trasmissione meccanica</i> Velocità di avanzamento (indicativa) a 3000 min ⁻¹	km/h	2,2 ÷ 9,7	2,2 ÷ 9,7
[15]	<i>Trasmissione idrostatica</i> Velocità di avanzamento (indicativa) a 3000 min ⁻¹	km/h	0 ÷ 8,8	0 ÷ 8,8
[16]	Limite di velocità con catene da neve (se accessorio previsto)	km/h	9,7	9,7
[17]	Dimensioni			
[18]	Lunghezza	mm	1647	1647 ÷ 1697
[19]	Lunghezza con sacco (Lunghezza senza sacco)	mm	- -	- -
[20]	Larghezza	mm	-	-
[21]	Larghezza con deflettore di scarico laterale (Larghezza senza deflettore di scarico laterale)		1198 (1051)	1312 (1101)
[22]	Altezza	mm	1068	1068
[23]	Codice dispositivo di taglio		82004346/0	82004357/0
[24]	Capacità del serbatoio carburante	l	6,5	6,5
[25]	Limite di carico per dispositivo di traino (Forza verticale massima)	N (kg)	245 (25)	245 (25)
[26]	Limite di carico per dispositivo di traino (Peso massimo rimorchiabile)	N (kg)	980 (100)	980 (100)
[27]	Inclinazione massima consentita		10° (17%)	10° (17%)
[28]	Livello di pressione acustica	dB(A)	83,8	87
[29]	Incertezza di misura	dB(A)	0,3	2,5
[30]	Livello di potenza acustica misurato	dB(A)	99	99
[29]	Incertezza di misura	dB(A)	0,8	0,43
[31]	Livello di potenza acustica garantito	dB(A)	100	100
[32]	Livello di vibrazioni al posto di guida	m/s ²	0,94	1,2
[29]	Incertezza di misura	m/s ²	1,39	0,52
[33]	Livello di vibrazioni al volante	m/s ²	3,33	3
[29]	Incertezza di misura	m/s ²	2,72	2

* Per il dato specifico, fare riferimento a quanto indicato nell'etichetta di identificazione della macchina.

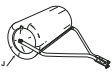
[1]	DATI TECNICI		MP 84 Series	MP 98 Series
[2]	Potenza nominale *	kW	5,56 ÷ 9,7	6,3 ÷ 11,45
[3]	Giri al minuto *	min ⁻¹	2300/2400 ± 100	2600 ± 100
[4]	Impianto elettrico	V	12	12
[5]	Pneumatici anteriori		13 x 5,00-6 (15 x 5,00-6)	13 x 5,00-6 (15 x 5,00-6)
[6]	Pneumatici posteriori		18 x 8,50-8 (18 x 6,50-8)	18 x 8,50-8 (18 x 6,50-8)
[7]	Pressione gonfiaggio anteriore 13 x 5,00-6 15 x 5,00-6	bar bar	1,5 1,0	1,5 1,0
[8]	Pressione gonfiaggio posteriore	bar	1,2	1,2
[9]	Massa *	kg	180 ÷ 187	185 ÷ 200
[10]	Raggio minimo di erba non tagliata	cm	80	70
[11]	Altezza di taglio	cm	3 ÷ 8,5	3 ÷ 8,5
[12]	Larghezza di taglio	cm	83	97
[13]	Capacità del sacco di raccolta	l	210 ÷ 240	210 ÷ 240
[14]	Trasmissione meccanica Velocità di avanzamento (indicativa) a 3000 min ⁻¹	km/h	2,2 ÷ 9,7	2,2 ÷ 9,7
[15]	Trasmissione idrostatica Velocità di avanzamento (indicativa) a 3000 min ⁻¹	km/h	0 ÷ 8,8	0 ÷ 8,8
[16]	Limite di velocità con catene da neve (se accessorio previsto)	km/h	9,7	9,7
[17]	Dimensioni			
[18]	Lunghezza	mm	-	-
[19]	Lunghezza con sacco (Lunghezza senza sacco)	mm	2217 ÷ 2340 (1814)	2340 (1814)
[20]	Larghezza	mm	902	1020
[21]	Larghezza con deflettore di scarico laterale (Larghezza senza deflettore di scarico laterale)		-	-
[22]	Altezza	mm	1098	1098
[23]	Codice dispositivo di taglio		82004358/0 - 82004359/0 82004360/0 - 82004361/0	82004362/0 - 82004363/0 82004346/0 - 82004364/0
[24]	Capacità del serbatoio carburante	l	6,5	6,5
[25]	Limite di carico per dispositivo di traino (Forza verticale massima)	N (kg)	245 (25)	245 (25)
[26]	Limite di carico per dispositivo di traino (Peso massimo rimorchiabile)	N (kg)	980 (100)	980 (100)
[27]	Inclinazione massima consentita		10° (17%)	10° (17%)
[28]	Livello di pressione acustica	dB(A)	86	86
[29]	Incertezza di misura	dB(A)	1,1	2,5
[30]	Livello di potenza acustica misurato	dB(A)	100	100
[29]	Incertezza di misura	dB(A)	0,63	0,65
[31]	Livello di potenza acustica garantito	dB(A)	100	100
[32]	Livello di vibrazioni al posto di guida	m/s ²	1,06	0,7
[29]	Incertezza di misura	m/s ²	0,99	0,25
[33]	Livello di vibrazioni al volante	m/s ²	6,37	8,2
[29]	Incertezza di misura	m/s ²	2,19	1,53

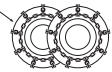
* Per il dato specifico, fare riferimento a quanto indicato nell'etichetta di identificazione della macchina.

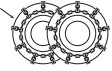
[42]	ACCESSORI A RICHIESTA	
[42.A1] [42.A2]	Kit "mulching"	✓
[42.B]	Carica batteria di mantenimento	✓
[42.C]	Kit traino	✓
[42.D]	Telo di copertura	✓
[42.E]	Kit di protezione scarico posteriore <i>(solo per modelli MP series)</i>	✓
[42.F]	Catene da neve (18")	✓
[42.G]	Ruote da fango/neve (18")	✓
[42.H]	Rimorchio	45-03453-997
[42.I]	Spargitore	45-03153-997
[42.J]	Rullo per erba	45-0267 45-02681
[42.K]	Spalaneve a lama	ST-1402
[42.L]	Raccogliitore foglie ed erba 38" <i>(solo per modelli SD series)</i>	45-03313-997
[42.L]	Raccogliitore foglie ed erba 42" <i>(solo per modelli SD series)</i>	45-02616-997

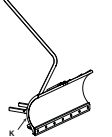
[34] TABELLA PER LA CORRETTA COMBINAZIONE DEGLI ACCESSORI							
		[34.A] ACCESSORI POSTERIORI					
							
		[42.H]	[42.I]	[42.J]	[42.L]	[42.F]	[42.G]
[34.B] ACCESSORI FRONTALI	 [42.F]	✓	✓	-	-	-	-
	 [42.G]	✓	✓	-	-	-	-
	 [42.K]	-	✓	-	-	✓	✓

<p>[1] BG - ТЕХНИЧЕСКИ ДАННИ</p> <p>[2] Номинална мощност *</p> <p>[3] Обороти в минута (*)</p> <p>[4] Електрическа система</p> <p>[5] Предни гуми</p> <p>[6] Задни гуми</p> <p>[7] Налягане предно напопване</p> <p>[8] Налягане задно напопване</p> <p>[9] Маса (*)</p> <p>[10] Минимален радиус на неподрязана трева</p> <p>[11] Височина на косене</p> <p>[12] Ширина на косене</p> <p>[13] Вместимост на торбата за събиране на трева</p> <p>[14] Механична трансмисия - Скорост на напредване (индикативна) - 3000 min⁻¹</p> <p>[15] Хидростатична трансмисия - Скорост на напредване (индикативна) - 3000 min⁻¹</p> <p>[16] Граница на скоростта с верига за сняг (ако тази принадлежност е предвидена)</p> <p>[17] Размери</p> <p>[18] Дължина</p> <p>[19] Дължина с торбата за събиране на трева (дължина без торбата за събиране на трева)</p> <p>[20] Ширина</p> <p>[21] Ширина с дефлектор на страничното разтоварване (Ширина без дефлектор на страничното разтоварване)</p> <p>[22] Височина</p> <p>[23] Код на инструмента за рязане</p> <p>[24] Вместимост на резервоара за гориво</p> <p>[25] Ограничение на товара за телгещото устройство (максимална вертикална сила)</p> <p>[26] Ограничение на товара за телгещото устройство (максимално тегло за телгене)</p> <p>[27] Максимално допустим наклон</p> <p>[28] Ниво на звуково налягане</p> <p>[29] Несигурност на измерване</p> <p>[30] Измерено ниво на акустична мощност</p> <p>[31] Гарантирано ниво на акустична мощност</p> <p>[32] Ниво на вибрации в мястото за управление</p> <p>[33] Ниво на вибрации на волана</p> <p>[34] Таблица за правилното комбинирание на принадлежностите</p> <p>[34.A] задни принадлежности</p> <p>[34.B] челни принадлежности</p> <p>[42] принадлежности по поръчка</p> <p>[42.A1, 42.A2] Набор за "mulching"</p> <p>[42.B] Зарядно устройство за поддръжане</p> <p>[42.C] Набор за телгене</p> <p>[42.D] Покривен брезент</p> <p>[42.E] Набор защита на задно разтоварване (само за модели от серията MP)</p> <p>[42.F] Вериги за сняг (18")</p> <p>[42.G] Колела за кал / сняг (18")</p> <p>[42.H] Ремарке</p> <p>[42.I] Приспособление за разсейване на пясък или чакъл</p> <p>[42.J] Ролка за трева</p> <p>[42.K] Снегорин с острие</p> <p>[42.L] Събирач на листа и трева (само за модели от серията SD)</p>	<p>[1] BS - TEHNIČKI PODACI</p> <p>[2] Nazivna snaga (*)</p> <p>[3] Obrtaji u minuti (*)</p> <p>[4] Električna instalacija</p> <p>[5] Prednje gume</p> <p>[6] Zadnje gume</p> <p>[7] Pritisak vazduha u prednjim gumama</p> <p>[8] Pritisak vazduha u zadnjim gumama</p> <p>[9] Masa (*)</p> <p>[10] Minimalan radijus nepokošene trave</p> <p>[11] Visina košenja</p> <p>[12] Širina košenja</p> <p>[13] Kapacitet vreće za skupljanje trave</p> <p>[14] Mehanički prijenos Brzina kretanja (orijentaciono) na 3000 min⁻¹</p> <p>[15] Hidrostatički prijenos Brzina kretanja (orijentaciono) na 3000 min⁻¹</p> <p>[16] Ograničenje brzine s lancima za snijeg (ako su oni predviđena dodatna oprema)</p> <p>[17] Dimenzije</p> <p>[18] Dužina</p> <p>[19] Dužina s vrećom (dužina bez vreće)</p> <p>[20] Širina</p> <p>[21] Širina s usmjerivačem bočnog izbacivanja (Širina bez usmjerivača bočnog izbacivanja)</p> <p>[22] Visina</p> <p>[23] Šifra rezne glave</p> <p>[24] Kapacitet spremnika goriva</p> <p>[25] Granica nosivosti uređaja za vuču (maksimalna vertikalna sila)</p> <p>[26] Granica nosivosti uređaja za vuču (maksimalna težina koja se smije vući)</p> <p>[27] Maksimalni dozvoljen nagib</p> <p>[28] Razina zvučnog pritiska</p> <p>[29] Mjerna nesigurnost</p> <p>[30] Izmjerena razina zvučne snage</p> <p>[31] Garantirana razina zvučne snage</p> <p>[32] Razina vibracija na mjestu vozača</p> <p>[33] Razina vibracija na volanu</p> <p>[34] Tablica za pravilno kombinovanje dodatne opreme</p> <p>[34.A] Zadnja dodatna oprema</p> <p>[34.B] Prednja dodatna oprema</p> <p>[42] Dodatna oprema na zahtjev</p> <p>[42.A1, 42.A2] Komplet za malčiranje</p> <p>[42.B] Punjač akumulatora za održavanje</p> <p>[42.C] Komplet za vuču</p> <p>[42.D] Pokrovna cerada</p> <p>[42.E] Komplet štitnika za izbacivanje odotraga (samo za seriju modela MP)</p> <p>[42.F] Lanci za snijeg (18")</p> <p>[42.G] Točkovi za blato / snijeg (18")</p> <p>[42.H] Prikolica</p> <p>[42.I] Rasipač</p> <p>[42.J] Valjak za travu</p> <p>[42.K] Plug za snijeg s nožem</p> <p>[42.L] Skupljač lišća i trave (samo za seriju modela SD)</p> <p>* Za specifični podatak, pogledajte što je navedeno na identifikacionoj naljepnici mašine</p>	<p>[1] CS - TECHNICKÉ PARAMETRY</p> <p>[2] Jmenovitý výkon (*)</p> <p>[3] Otáčky za minutu (*)</p> <p>[4] Elektroinstalace</p> <p>[5] Přední pneumatiky</p> <p>[6] Zadní pneumatiky</p> <p>[7] Tlak huštění předních pneumatik</p> <p>[8] Tlak huštění zadních pneumatik</p> <p>[9] Hmotnost (*)</p> <p>[10] Minimální poloměr neposečené trávy</p> <p>[11] Výška sekání</p> <p>[12] Šířka sekání</p> <p>[13] Kapacita sběrného koše</p> <p>[14] Mechanická převodovka Rychlost jejezdu (přibližná) při 3000 min⁻¹</p> <p>[15] Hydrostatická převodovka Rychlost jejezdu (přibližná) při 3000 min⁻¹</p> <p>[16] Mezní rychlost se sněhovými řetězy (pokud se jedná o určené příslušenství)</p> <p>[17] Rozměry</p> <p>[18] Délka</p> <p>[19] Délka s košem (Délka bez koše)</p> <p>[20] Šířka</p> <p>[21] Šířka vychylovače bočního výhozu (Šířka bez vychylovače bočního výhozu)</p> <p>[22] Výška</p> <p>[23] Kód sekacího zařízení</p> <p>[24] Kapacita palivové nádržky</p> <p>[25] Mezní zatížení tažného zařízení (max. svislá síla)</p> <p>[26] Mezní zatížení tažného zařízení (max. tažená hmotnost)</p> <p>[27] Maximální povolené naklonění</p> <p>[28] Úroveň akustického tlaku</p> <p>[29] Nepřesnost měření</p> <p>[30] Úroveň naměřeného akustického výkonu</p> <p>[31] Úroveň zaručeného akustického výkonu</p> <p>[32] Úroveň vibrací na místě řidiče</p> <p>[33] Úroveň vibrací na volantu</p> <p>[34] Tabulka pro správnou kombinaci příslušenství</p> <p>[34.A] Zadní příslušenství</p> <p>[34.B] Přední příslušenství</p> <p>[42] Příslušenství na požádání</p> <p>[42.A1, 42.A2] Sada pro mulčování</p> <p>[42.B] Udržovací nabíječka akumulátoru</p> <p>[42.C] Sada tažného zařízení</p> <p>[42.D] Krycí plachta</p> <p>[42.E] Sada ochranného krytu zadního výhozu (jen pro modely řady MP)</p> <p>[42.F] Sněhové řetězy (18")</p> <p>[42.G] Kola do bláta / sněhu (18")</p> <p>[42.H] Přívěs</p> <p>[42.I] Pospývač</p> <p>[42.J] Válec pro válcování trávy</p> <p>[42.K] Sněhová radlice</p> <p>[42.L] Sběrač listů a trávy (jen pro modely řady SD)</p> <p>* Ohledně uvedeného údaje vycházejte z hodnoty uvedené na identifikačním štítku stroje.</p>
---	---	--

<p>[1] DA - TEKNISKE DATA</p> <p>[2] Nominel effekt (*)</p> <p>[3] Omdrejninger pr. minut (*)</p> <p>[4] Elektrisk anlæg</p> <p>[5] Forhjulsdæk</p> <p>[6] Baghjulsdæk</p> <p>[7] Pumpetryk for fordæk</p> <p>[8] Pumpetryk for bagdæk</p> <p>[9] Vægt (*)</p> <p>[10] Minimumsradius af ikke klippet græs</p> <p>[11] Klippehøjde</p> <p>[12] Klippebredde</p> <p>[13] Størrelse på opsamlingspose</p> <p>[14] Mekanisk transmission Fremdriftshastighed (vejledende) ved 3000 min⁻¹</p> <p>[15] Hydrostatisk transmission Fremdriftshastighed (vejledende) ved 3000 min⁻¹</p> <p>[16] Hastighedsgrænse med snekæder (hvis disse er monteret)</p> <p>[17] Mål</p> <p>[18] Længde</p> <p>[19] Længde med opsamlingspose (længde uden pose)</p> <p>[20] Bredde</p> <p>[21] Bredde med sideudkast skærm (Hvis monteret)</p> <p>[22] Højde</p> <p>[23] Skæreanordningens varenr.</p> <p>[24] Brændstoftankens kapacitet</p> <p>[25] Belastningsgrænse for trækanordning (maksimal, vertikal effekt)</p> <p>[26] Belastningsgrænse for trækanordning (maksimal anhængervægt)</p> <p>[27] Maksimal tilladt hældning</p> <p>[28] Lydtryksniveau</p> <p>[29] Måleusikkerhed</p> <p>[30] Målt lydeffektniveau</p> <p>[31] Garanteret lydeffektniveau</p> <p>[32] Vibrationsniveau på førersædet</p> <p>[33] Vibrationsniveau ved rattet</p> <p>[34] Tabel over udstyrets korrekte kombination</p> <p>[34.A] Bagmonteret tilbehør</p> <p>[34.B] Formonteret tilbehør</p> <p>[42] Ekstraudstyr</p> <p>[42.A1, 42.A2] Sæt til "Multiclip"</p> <p>[42.B] Udligningsbatterilader</p> <p>[42.C] Sæt til bugsering</p> <p>[42.D] Presenning</p> <p>[42.E] Sæt til beskyttelse på bagudkast (<i>bare for MP serie modeller</i>)</p> <p>[42.F] Snekæder (18")</p> <p>[42.G] Mudder- og snehjul (18")</p> <p>[42.H] Anhænger</p> <p>[42.I] Fordeler</p> <p>[42.J] Græsvalse</p> <p>[42.K] Sneplov med skraberør</p> <p>[42.L] Opsamlingsmaskine til blade og græs (<i>bare for SD serie modeller</i>)</p>	<p>[1] DE - TECHNISCHE DATEN</p> <p>[2] Nennleistung (*)</p> <p>[3] Umdrehungen pro Minute (*)</p> <p>[4] Elektrische Anlage</p> <p>[5] Reifen Vorderräder</p> <p>[6] Reifen Hinterräder</p> <p>[7] Reifendruck vorne</p> <p>[8] Reifendruck hinten</p> <p>[9] Gewicht (*)</p> <p>[10] Mindestradius nicht geschneittenes Gras</p> <p>[11] Schnitthöhe</p> <p>[12] Schnittbreite</p> <p>[13] Fassungsvermögen der Grasfangeinrichtung</p> <p>[14] Mechanischer Antrieb - Vorschubgeschwindigkeit (Richtwert) bei 3000 min⁻¹</p> <p>[15] Hydrostatischer Antrieb - Vorschubgeschwindigkeit (Richtwert) bei 3000 min⁻¹</p> <p>[16] Geschwindigkeitsgrenze mit Schneeketten (falls als Zubehör vorgesehen)</p> <p>[17] Abmessungen</p> <p>[18] Länge</p> <p>[19] Länge mit Grasfangeinrichtung (Länge ohne Grasfangeinrichtung)</p> <p>[20] Breite</p> <p>[21] Breite mit seitlichem Auswurfdeflektor (Breite ohne seitlichen Auswurfdeflektor)</p> <p>[22] Höhe</p> <p>[23] Code Schneidwerkzeug</p> <p>[24] Inhalt des Kraftstofftanks</p> <p>[25] Lastgrenze für Zugvorrichtung (max. senkrechte Kraft)</p> <p>[26] Lastgrenze für Zugvorrichtung (max. Zuggewicht)</p> <p>[27] Max. zulässige Neigung</p> <p>[28] Schalldruckpegel</p> <p>[29] Messungenauigkeit</p> <p>[30] Gemessener Schalleistungspegel</p> <p>[31] Garantierter Schalleistungspegel</p> <p>[32] Vibrationspegel am Fahrersitz</p> <p>[33] Vibrationspegel am Lenkrad</p> <p>[34] übersicht für die korrekte zubehörkombination</p> <p>[34.A] Heckseitiges zubehör</p> <p>[34.B] Frontseitiges zubehör</p> <p>[42] Sonderzubehör</p> <p>[42.A1, 42.A2] "Mulching"-kit</p> <p>[42.B] Batterieladegerät</p> <p>[42.C] Zugvorrichtung</p> <p>[42.D] Abdeckung</p> <p>[42.E] Kit hinterer auswurfschutz (<i>nur für MP-Series</i>)</p> <p>[42.F] Schneeketten (18")</p> <p>[42.G] M+S-Räder (Matsch- und Schneeräder) (18")</p> <p>[42.H] Anhänger</p> <p>[42.I] Streuer</p> <p>[42.J] Rasenwalze</p> <p>[42.K] Schneepflug</p> <p>[42.L] Sammler für laub und gras (<i>nur für SD-Series</i>)</p>	<p>[1] EL - ΤΕΧΝΙΚΑ ΧΑΡΑΚΤΗΡΙΣΤΙΚΑ</p> <p>[2] Ονομαστική ισχύς (*)</p> <p>[3] Στροφές ανά λεπτό (*)</p> <p>[4] Ηλεκτρικό σύστημα</p> <p>[5] Εμπρόσθια ελαστικά</p> <p>[6] Πίσω ελαστικά</p> <p>[7] Πίεση εμπρόσθων ελαστικών</p> <p>[8] Πίεση πίσω ελαστικών</p> <p>[9] Βάρος (*)</p> <p>[10] Ελάχιστη ακτίνα μη κομμένου χόρτου</p> <p>[11] Ύψος κοπής</p> <p>[12] Πλάτος κοπής</p> <p>[13] Χωρητικότητα του κάδου περισυλλογής</p> <p>[14] Μηχανικό σύστημα μετάδοσης Ταχύτητα κίνησης (ενδεικτική) στις 3000 σ.α.λ.</p> <p>[15] Υδροστατικό σύστημα μετάδοσης Ταχύτητα κίνησης (ενδεικτική) στις 3000 σ.α.λ.</p> <p>[16] Όριο ταχύτητας με αλυσίδες χιονίου (αν προβλέπεται ως αξεσουάρ)</p> <p>[17] Διαστάσεις</p> <p>[18] Μήκος</p> <p>[19] Μήκος με κάδο (μήκος χωρίς κάδο)</p> <p>[20] Πλάτος</p> <p>[21] Πλάτος με πλευρικό εκτροπέα αποβολής (Πλάτος χωρίς πλευρικό εκτροπέα αποβολής)</p> <p>[22] Ύψος</p> <p>[23] Κωδικός συστήματος κοπής</p> <p>[24] Χωρητικότητα του ντεπόζιτου καυσίμου</p> <p>[25] Όριο φορτίου για το σύστημα ρυμούλκησης (μέγιστη κάθεται δύναμη)</p> <p>[26] Όριο φορτίου για το σύστημα ρυμούλκησης (μέγιστη ρυμουλκούμενο βάρος)</p> <p>[27] Μέγιστη επιτρεπόμενη γωνία</p> <p>[28] Στάθμη ακουστικής πίεσης</p> <p>[29] Αβεβαιότητα μέτρησης</p> <p>[30] Μετρημένη στάθμη ακουστικής ισχύος</p> <p>[31] Εγγυημένη στάθμη ακουστικής ισχύος</p> <p>[32] Επίπεδο κραδασμών στη θέση του οδηγού</p> <p>[33] Επίπεδο κραδασμών στο τιμόνι</p> <p>[34] σωστός κρινακας για το σωστο συνδιασμο των παρελκομενων</p> <p>[34.A] οπισθια παρελκομενα</p> <p>[34.B] εμπροσθια παρελκομενα</p> <p>[42] αιτουμενα παρελκομενα</p> <p>[42.A1, 42.A2] Σετ "mulching"</p> <p>[42.B] Φορτιστής συντήρησης μπαταρίας</p> <p>[42.C] Σετ ρυμούλκησης</p> <p>[42.D] Κάλυμμα προστασίας</p> <p>[42.E] Σετ προστασίας οπισθίας αποβολής (<i>μόνο για τα μοντέλα της σειράς MP</i>)</p> <p>[42.F] Αλυσίδες χιονίου (18")</p> <p>[42.G] Τροχοί για λάσπη / χόνι (18")</p> <p>[42.H] Ρυμουλκούμενο</p> <p>[42.I] Διανομέας</p> <p>[42.J] Κυλινδρος για χλοη</p> <p>[42.K] Εκχιονιστικό με λάμα</p> <p>[42.L] Συλλεκτής φυλλων και χλοης (<i>μόνο για τα μοντέλα της σειράς SD</i>)</p>
<p>* For disse data henvises til hvad der er angivet på maskinens identifikationsmærkat.</p>	<p>* Für die genaue Angabe nehmen Sie bitte auf das Typenschild der Maschine Bezug</p>	<p>* Για το συγκεκριμένο στοιχείο, ελέγξτε τα όσα αναγράφονται στην ετικέτα προορισμού του μηχανήματος</p>

<p>[1] EN - TECHNICAL DATA</p> <p>[2] Nominal power (*)</p> <p>[3] RPM (*)</p> <p>[4] Electrical system</p> <p>[5] Front tyres</p> <p>[6] Rear tyres</p> <p>[7] Front tyre pressure</p> <p>[8] Rear tyre pressure</p> <p>[9] Mass (*)</p> <p>[10] Minimum radius of uncut grass</p> <p>[11] Cutting height</p> <p>[12] Cutting width</p> <p>[13] Grass catcher capacity</p> <p>[14] Mechanical transmission Forward speed (approximate) at 3000 min⁻¹</p> <p>[15] Hydrostatic transmission Forward speed (approximate) at 3000 min⁻¹</p> <p>[16] Speed limit with snow chains (if available)</p> <p>[17] Dimensions</p> <p>[18] Length</p> <p>[19] Length with grass catcher (length without grass catcher)</p> <p>[20] Width</p> <p>[21] Width with side discharge chute (Width without side discharge chute)</p> <p>[22] Height</p> <p>[23] Cutting means code</p> <p>[24] Fuel tank capacity</p> <p>[25] Admissible load on towing device (maximum vertical weight)</p> <p>[26] Admissible load for towing device (maximum towing weight)</p> <p>[27] Maximum admissible tilt</p> <p>[28] Acoustic pressure level</p> <p>[29] Measurement uncertainty</p> <p>[30] Measured acoustic power level</p> <p>[31] Guaranteed acoustic power level</p> <p>[32] Operator position vibration level</p> <p>[33] Steering wheel vibration level</p> <p>[34] Table for correct accessory combinations</p> <p>[34.A] Rear accessories</p> <p>[34.B] Front accessories [42] Accessories available on request</p> <p>[42.A1, 42.A2] "Mulching" kit</p> <p>[42.B] Maintenance battery charger</p> <p>[42.C] Towing kit</p> <p>[42.D] Cloth cover</p> <p>[42.E] Rear discharge guard kit (<i>only for MP series</i>)</p> <p>[42.F] Snow chains (18")</p> <p>[42.G] Mud / Snow wheels (18")</p> <p>[42.H] Trailer</p> <p>[42.I] Sprinkler</p> <p>[42.J] Lawn roller</p> <p>[42.K] Snow shovel</p> <p>[42.L] Leaf and grass catcher (<i>only for SD series</i>)</p>	<p>[1] ES - DATOS TÉCNICOS</p> <p>[2] Potencia nominal (*)</p> <p>[3] Revoluciones por minuto (*)</p> <p>[4] Instalación eléctrica</p> <p>[5] Neumáticos anteriores</p> <p>[6] Neumáticos posteriores</p> <p>[7] Presión neumático anterior</p> <p>[8] Presión neumático posterior</p> <p>[9] Masa (*)</p> <p>[10] Radio mínimo de hierba no cortada</p> <p>[11] Altura de corte</p> <p>[12] Anchura de corte</p> <p>[13] Capacidad de la bolsa de recolección</p> <p>[14] Transmisión mecánica Velocidad de avance (indicativa) a 3000 min⁻¹</p> <p>[15] Transmisión hidrostática Velocidad de avance (indicativa) a 3000 min⁻¹</p> <p>[16] Límite de velocidad con cadenas de nieve (si estuviera previsto el accesorio)</p> <p>[17] Dimensiones</p> <p>[18] Longitud</p> <p>[19] Longitud con bolsa (longitud sin bolsa)</p> <p>[20] Anchura</p> <p>[21] Ancho con deflector de descarga lateral (ancho sin deflector de descarga lateral)</p> <p>[22] Altura</p> <p>[23] Código dispositivo de corte</p> <p>[24] Capacidad del depósito carburante</p> <p>[25] Límite de carga para dispositivo de remolque (fuerza vertical máxima)</p> <p>[26] Límite de carga para dispositivo de remolque (peso máximo de remolque)</p> <p>[27] Inclinación máxima permitida</p> <p>[28] Nivel de presión acústica</p> <p>[29] Incertidumbre de medida</p> <p>[30] Nivel de potencia acústica medido</p> <p>[31] Nivel de potencia acústica garantizado</p> <p>[32] Nivel de vibraciones en el puesto de conductor</p> <p>[33] Nivel de vibraciones al volante</p> <p>[34] Tabla para combinar accesorios</p> <p>[34.A] Accesorios traseros</p> <p>[34.B] Accesorios frontales</p> <p>[42] Accesorios bajo pedido</p> <p>[42.A1, 42.A2] Kit para "mulching"</p> <p>[42.B] Cargador de batería de mantenimiento</p> <p>[42.C] Kit remolque</p> <p>[42.D] Lona de cubierta</p> <p>[42.E] Kit sistema de seguridad de descarga posterior (<i>sólo para la serie MP</i>)</p> <p>[42.F] Cadenas de nieve (18")</p> <p>[42.G] Ruedas para fango y nieve (18")</p> <p>[42.H] Remolque</p> <p>[42.I] Esparcidor</p> <p>[42.J] Rodillo para hierba</p> <p>[42.K] Quitanieves de cuchilla</p> <p>[42.L] Recogedor hojas y hierba (<i>sólo para la serie SD</i>)</p>	<p>[1] FI - TEKNISET TIEDOT</p> <p>[2] Nimellisteho (*)</p> <p>[3] Kierrosta minuutissa (*)</p> <p>[4] Sähkölaitteisto</p> <p>[5] Eturenkaat</p> <p>[6] Takarenkaat</p> <p>[7] Eturenkaiden täyttöpaine</p> <p>[8] Takarenkaiden täyttöpaine</p> <p>[9] Massa (*)</p> <p>[10] Löikämata rohu minimaalhe raadiusi</p> <p>[11] Leikkuukorkeus</p> <p>[12] Leikkuuleveys</p> <p>[13] Keruusaknin tilavuus</p> <p>[14] Mekaaninen voimansiirto Eteneemisnopeus (suuntaa-antava) 3000 min⁻¹</p> <p>[15] Hydrostaattinen voimansiirto Eteneemisnopeus (suuntaa-antava) 3000 min⁻¹</p> <p>[16] Nopeusrajoitus lumiketjuilla (jos kuuluu lisävarusteisiin)</p> <p>[17] Mitat</p> <p>[18] Pituus</p> <p>[19] Pituus säkin kanssa (pituus ilman säkkiä)</p> <p>[20] Leveys</p> <p>[21] Sivutyhjennyksen läppäkorkin leveys (Leveys ilman sivutyhjennyksen läppäkorkkia)</p> <p>[22] Korkeus</p> <p>[23] Leikkuuvälineen koodi</p> <p>[24] Polttoainesäiliön tilavuus</p> <p>[25] Vetolaitteen kuormituksen raja-arvo (enimmäispystyvoima)</p> <p>[26] Vetolaitteen kuormituksen raja-arvo (kiinnitettävä enimmäispaino)</p> <p>[27] Suurin sallittu kaltevuus</p> <p>[28] Akustisen paineen taso</p> <p>[29] Mittauksen epävarmuus</p> <p>[30] Mittattu äänitehotaso</p> <p>[31] Taattu äänitehotaso</p> <p>[32] Tärinätaaso kuljettajan paikalla</p> <p>[33] Tärinätaaso ohjauspyörässä</p> <p>[34] Lisävarusteiden oikeaoppisen yhdistelyn taulukko</p> <p>[34.A] Takavaruste</p> <p>[34.B] Etuvaruste</p> <p>[42] Tilattavat lisävarusteet</p> <p>[42.A1, 42.A2] Silppuunavarusteet</p> <p>[42.B] Yläpitoakkulaturi</p> <p>[42.C] hinaussarja</p> <p>[42.D] Suojakangas</p> <p>[42.E] Takatyhjennyksen suojuussarja (<i>pelkästään MP series</i>)</p> <p>[42.F] Lumiketjut (18")</p> <p>[42.G] Muta-/talvipyörät (18")</p> <p>[42.H] Perävaunu</p> <p>[42.I] Levitin</p> <p>[42.J] Nurmikkojyrä</p> <p>[42.K] Lumiaura</p> <p>[42.L] Lehtien ja ruohon kerääjä (<i>pelkästään SD series</i>)</p>
<p>* Please refer to the data indicated on the machine's identification plate for the exact figure.</p>	<p>* Para el dato específico, hacer referencia a lo indicado en la etiqueta de identificación de la máquina.</p>	<p>* Määrättyä arvoa varten, viittaa laitteen tunnuslaatassa annettuihin tietoihin.</p>

<p>[1] FR - CARACTÉRISTIQUES TECHNIQUES</p> <p>[2] Puissance nominale (*)</p> <p>[3] Tours par minute (*)</p> <p>[4] Installation électrique</p> <p>[5] Pneus avant</p> <p>[6] Pneus arrière</p> <p>[7] Pression de gonflage avant</p> <p>[8] Pression de gonflage arrière</p> <p>[9] Masse (*)</p> <p>[10] Rayon minimal de l'herbe non taillée</p> <p>[11] Hauteur de coupe</p> <p>[12] Largeur de coupe</p> <p>[13] Capacité du bac de ramassage</p> <p>[14] Transmission mécanique Vitesse d'avancement (indicative) à 3000 min⁻¹</p> <p>[15] Transmission hydrostatique Vitesse d'avancement (indicative) à 3000 min⁻¹</p> <p>[16] Limite de vitesse avec chaînes à neige (si accessoire prévu)</p> <p>[17] Dimensions</p> <p>[18] Longueur</p> <p>[19] Longueur avec sac (longueur sans sac)</p> <p>[20] Largeur</p> <p>[21] Largeur avec déflecteur d'éjection latérale (Largeur sans déflecteur d'éjection latérale)</p> <p>[22] Hauteur</p> <p>[23] Code organe de coupe</p> <p>[24] Capacité du réservoir de carburant</p> <p>[25] Limite de charge pour dispositif de remorquage (force verticale maximale)</p> <p>[26] Limite de charge pour dispositif de remorquage (poids maximum remorquable)</p> <p>[27] Pente maximale admise</p> <p>[28] Niveau de pression acoustique</p> <p>[29] Incertitude de mesure</p> <p>[30] Niveau de puissance acoustique mesuré</p> <p>[31] Niveau de puissance acoustique garanti</p> <p>[32] Niveau de vibration au poste de conduite</p> <p>[33] Niveau de vibration au volant</p> <p>[34] Tableau pour la correcte combinaison des accessoires</p> <p>[34.A] Accessoires arrière</p> <p>[34.B] Accessoires frontaux</p> <p>[42] Accessoires sur demande</p> <p>[42.A.1, 42.A2] Kit pour "mulching"</p> <p>[42.B] Chargeur de batterie</p> <p>[42.C] Kit remorquage</p> <p>[42.D] Housse de protection</p> <p>[42.E] Kit protecteur d'éjection arrière (<i>seulement pour la série MP</i>)</p> <p>[42.F] Chaîne à neige (18")</p> <p>[42.G] Roues complètes boue / neige (18")</p> <p>[42.H] Remorque</p> <p>[42.I] Épandeur</p> <p>[42.J] Rouleau à gazon</p> <p>[42.K] Lame à neige</p> <p>[42.L] Balai de ramassage feuilles et herbe (<i>seulement pour la série SD</i>)</p>	<p>[1] HR - TEHNIČKI PODACI</p> <p>[2] Nazivna snaga (*)</p> <p>[3] Broj okretaja u minuti (*)</p> <p>[4] Električni sustav</p> <p>[5] Prednje gume</p> <p>[6] Stražnje gume</p> <p>[7] Tlak zraka u prednjim gumama</p> <p>[8] Tlak zraka u stražnjim gumama</p> <p>[9] Masa (*)</p> <p>[10] Minimalni promjer nepokošene trave</p> <p>[11] Visina košnje</p> <p>[12] Širina košnje</p> <p>[13] Kapacitet košare za sakupljanje trave</p> <p>[14] Mehanički prijenos Brzina napredovanja (indikativno) pri 3.000 min⁻¹</p> <p>[15] Hidrostatski prijenos Brzina napredovanja (indikativno) pri 3.000 min⁻¹</p> <p>[16] Ograničenje brzine s lancima za snijeg (ako se radi o predviđenom dijelu dodatne opreme)</p> <p>[17] Dimenzije</p> <p>[18] Dužina</p> <p>[19] Dužina s košarom (dužina bez košare)</p> <p>[20] Širina</p> <p>[21] Širina s usmjerivačem za bočno izbacivanje (Širina bez usmjerivača za bočno izbacivanje)</p> <p>[22] Visina</p> <p>[23] Šifra noža</p> <p>[24] Zapremina spremnika goriva</p> <p>[25] Granica nosivosti uređaja za vuču (maksimalna vertikalna sila)</p> <p>[26] Granica nosivosti uređaja za vuču (maksimalna težina koja se smije vući)</p> <p>[27] Maksimalni dozvoljen nagib</p> <p>[28] Razina zvučnog tlaka</p> <p>[29] Mjerna nesigurnost</p> <p>[30] Izmjerena razina zvučne snage</p> <p>[31] Zajamčena razina zvučne snage</p> <p>[32] Razina vibracija na vozačkom mjestu</p> <p>[33] Razina vibracija na upravljaču</p> <p>[34] Tablica za pravilno kombiniranje dodatnog pribora</p> <p>[34.A] Zadnji dodatni pribor</p> <p>[34.B] Prednji dodatni pribor</p> <p>[42] Dodatni pribor na upit</p> <p>[42.A.1, 42.A2] Komplet za "malčiranje"</p> <p>[42.B] Punjač baterija za održavanje</p> <p>[42.C] Komplet za vuču</p> <p>[42.D] Zaštitna cerada</p> <p>[42.E] Komplet za štitnik stražnjeg otvora za izbacivanje (<i>samo za MP serije</i>)</p> <p>[42.F] Lanci za snijeg (18")</p> <p>[42.G] Kotačić za blato/snijeg (18")</p> <p>[42.H] Prikolica</p> <p>[42.I] Rasipač</p> <p>[42.J] Valjak za travu</p> <p>[42.K] Nož za čišćenje snijega</p> <p>[42.L] Sakupljač lišća i trave (<i>samo za SD serije</i>)</p>	<p>[1] HU - MŰSZAKI ADATOK</p> <p>[2] Névleges teljesítmény (*)</p> <p>[3] Percenkénti fordulatszám (*)</p> <p>[4] Elektromos rendszer</p> <p>[5] Elülös gumibroncsok</p> <p>[6] Hátsós gumibroncsok</p> <p>[7] Elülös abroncsok légnnyomása</p> <p>[8] Hátsós abroncsok légnnyomása</p> <p>[9] Tömeg (*)</p> <p>[10] Nem levágott fű minimális sugara</p> <p>[11] Nyírási magasság</p> <p>[12] Munkaszélesség</p> <p>[13] A gyűjtőzsák térfogata</p> <p>[14] Mechanikus erőátvitel Haladási sebesség (hozzátétőlegesen) 3000 ford./perces fordulatszám</p> <p>[15] Hidrosztatikus erőátvitel Haladási sebesség (hozzátétőlegesen) 3000 ford./perces fordulatszám</p> <p>[16] Sebességkorlát hólánccal (ha tartozék)</p> <p>[17] Méretek</p> <p>[18] Hosszúság</p> <p>[19] Hosszúság zsákkal (hosszúság zsák nélkül)</p> <p>[20] Szélesség</p> <p>[21] Szélesség oldalsó kidobás deflektorral (Szélesség oldalsó kidobás deflektor nélkül)</p> <p>[22] Magasság</p> <p>[23] Vágóegység kódszáma</p> <p>[24] Üzemanyagtartály kapacitása</p> <p>[25] Vontatóberendezés maximális terhelése (maximális függőleges erőhatás)</p> <p>[26] Vontatóberendezés maximális terhelése (maximális vontatható súly)</p> <p>[27] Megengedett legnagyobb dőlés</p> <p>[28] Hangnyomásszint</p> <p>[29] Mérési bizonytalanság</p> <p>[30] Mért zajteljesítmény szint.</p> <p>[31] Garantált zajteljesítmény szint</p> <p>[32] A vezetőállásnál mért vibrációs szint</p> <p>[33] A kormányánál mért vibrációs szint</p> <p>[34] Tartozékok helyes kombinációja táblázat</p> <p>[34.A] Hátsó tartozékok</p> <p>[34.B] Front tartozékok</p> <p>[42] Rendelhető tartozékok</p> <p>[42.A.1, 42.A.2] "Mulcsoszó készlet"</p> <p>[42.B] Fenntartó akkumulátortöltő</p> <p>[42.C] Vontató készlet</p> <p>[42.D] Takaró ponyva</p> <p>[42.E] Hátsó kidobás védőréz készlet (<i>csak az MP sorozat</i>)</p> <p>[42.F] Hólánccok (18")</p> <p>[42.G] Sár- és hókezek (18")</p> <p>[42.H] Utánfutó</p> <p>[42.I] Szóró</p> <p>[42.J] Gyephenger</p> <p>[42.K] Hótiólap</p> <p>[42.L] Fű- és lombgyűjtő (<i>csak az SD sorozat</i>)</p> <p>* A pontos adatot lásd a gép azonosító adattábláján.</p>
<p>* Pour la valeur spécifique, se référer à ce qui est indiqué sur la plaque signalétique de la machine.</p>	<p>* Specifični podatak pogledajte na identifikacijskoj etiketi stroja.</p>	

<p>[1] LT - TECHNINIAI DUOMENYS</p> <p>[2] Vardinė galia (*)</p> <p>[3] Apsisukimai per minutę (*)</p> <p>[4] Elektros instaliacija</p> <p>[5] Priekinės padangos</p> <p>[6] Užpakalinės padangos</p> <p>[7] Priekinių padangų oro slėgis</p> <p>[8] Užpakalinių padangų oro slėgis</p> <p>[9] Svoris (*)</p> <p>[10] Mažiausias nenupjautos žolės spindulys</p> <p>[11] Pjovimo aukštis</p> <p>[12] Pjovimo plotis</p> <p>[13] Surinkimo maišo talpa</p> <p>[14] Mechaninė transmisija</p> <p>[15] Eigos greitis (apytikslis) per 3000 min⁻¹</p> <p>[15] Hidrostatinė transmisija</p> <p>[15] Eigos greitis (apytikslis) per 3000 min⁻¹</p> <p>[16] Greičio riba su sniego grandinėmis (jei šis priedas numatytas)</p> <p>[17] Matmenys</p> <p>[18] Ilgis</p> <p>[19] Ilgis su maišu (ilgis be maišo)</p> <p>[20] Plotis</p> <p>[21] Plotis su šoninio išmetimo deflektoriu (Plotis be šoninio išmetimo deflektoriaus)</p> <p>[22] Aukštis</p> <p>[23] Pjovimo įtaiso kodas</p> <p>[24] Alyvos bako talpa</p> <p>[25] Tempimo prietaiso svorio limitas (maksimali, vertikaliai veikianti vilkimo įrenginį jėga)</p> <p>[26] Tempimo prietaiso svorio limitas (maksimalus pakrautos priemonės svoris)</p> <p>[27] Maksimalus leistinas pokrypis</p> <p>[28] Garso slėgio lygis</p> <p>[29] Matavimo paklaida</p> <p>[30] Išmatuotas garso galios lygis</p> <p>[31] Garantuotas garso galios lygis</p> <p>[32] Vibracijų lygis, sėdyne</p> <p>[33] Vibracijų lygis, vairas</p> <p>[34] Teisingos priedų kombinacijos lentelė</p> <p>[34.A] Galiniai priedai</p> <p>[34.B] Priekiniai priedai</p> <p>[42] Priedai, kuriuos galima užsisakyti</p> <p>[42.A1, 42.A2] Rinkinys mulčiamalui</p> <p>[42.B] Akumuliatoriaus palaikymo</p> <p>[42.C] Rinkinys vilkimui</p> <p>[42.D] Apdangalas</p> <p>[42.E] Galinio išmetimo apsaugos įtaiso rinkinys (<i>tikai MP serija</i>)</p> <p>[42.F] Sniego grandinės (18")</p> <p>[42.G] Ratai purvui / sniegui (18")</p> <p>[42.H] Priekaba</p> <p>[42.I] Barstytuvas</p> <p>[42.J] Vejos volas</p> <p>[42.K] Peilinis sniego valytuvas</p> <p>[42.L] Lapų ir žolės surinktuvas (<i>tikai SD serija</i>)</p>	<p>[1] LV - TEHNISKIE DATI</p> <p>[2] Nominālā jauda (*)</p> <p>[3] Apgriezieni minūtē (*)</p> <p>[4] Elektroiekārta</p> <p>[5] Priekšējās riepas</p> <p>[6] Aizmugurējās riepas</p> <p>[7] Priekšējo riepu spiediēns</p> <p>[8] Aizmugurējo riepu spiediēns</p> <p>[9] Masa (*)</p> <p>[10] Minimālais nenopļautās zāles rādiuss</p> <p>[11] Pļaušanas augstums</p> <p>[12] Pļaušanas platums</p> <p>[13] Savākšanas maisa tilpums</p> <p>[14] Mehāniskā transmisija</p> <p>[15] Hidrostatiskā transmisija</p> <p>[15] Kustības ātrums (aptuvenus) pie 3000 min⁻¹</p> <p>[16] Ātruma ierobežojums sniega ķēžu izmantošanas gadījumā (ja šis piederums ir paredzēts)</p> <p>[17] Izmēri</p> <p>[18] Garums</p> <p>[19] Garums ar maišu (garums bez maisa)</p> <p>[20] Platums</p> <p>[21] Platums ar sāniskās izmešanas deflektoru (Platums bez sāniskās izmešanas deflektora)</p> <p>[22] Augstums</p> <p>[23] Griezējierīces kods</p> <p>[24] Degvielas tvertnes tilpums</p> <p>[25] Jūgierīces slodze limits (maksimālais vertikālais spēks)</p> <p>[26] Jūgierīces slodze limits (maksimālais piekabes svars)</p> <p>[27] Maksimālais pielāujamais slīpums</p> <p>[28] Skaņas spiediena līmenis</p> <p>[29] Mērījumu kļūda</p> <p>[30] Izmērtais skaņas intensitātes līmenis</p> <p>[31] Garantētais skaņas intensitātes līmenis</p> <p>[32] Vibrāciju līmenis vadītāja vietā</p> <p>[33] Stūres vibrāciju līmenis</p> <p>[34] Tabula pareizai piederumu kombinācijai</p> <p>[34.A] Aizmugures piederumi</p> <p>[34.B] Priekšējie piederumi</p> <p>[42] Piederumi pēc pieprasījuma</p> <p>[42.A1, 42.A2] Mulčēšanas komplekts</p> <p>[42.B] Akumulatoru atbalsta lādētājs</p> <p>[42.C] Vilkšanas komplekts</p> <p>[42.D] Pārvalks</p> <p>[42.E] Aizmugurējās izmešanas aizsarga komplekts (<i>tik MP serijos</i>)</p> <p>[42.F] Sniega ķēdes (18")</p> <p>[42.G] Dubļu/sniega riteņi (18")</p> <p>[42.H] Piekabe</p> <p>[42.I] Izklīdētājs</p> <p>[42.J] Zāles rullis</p> <p>[42.K] Sniega tīrītājs ar vērstuvi</p> <p>[42.L] Lapu un zāles savācējs (<i>tik SD serijos</i>)</p> <p>* Precīza vērtība ir norādīta mašīnas identifikācijas datu plāksnītē.</p>	<p>[1] МК - ТЕХНИЧКИ ПОДАТОЦИ</p> <p>[2] Номинална моќност (*)</p> <p>[3] Вртежи во минута (*)</p> <p>[4] Електрична инсталација</p> <p>[5] Предни пневматици</p> <p>[6] Задни пневматици</p> <p>[7] Притисок за полнење напред</p> <p>[8] Притисок за полнење назад</p> <p>[9] Тежина (*)</p> <p>[10] Минимален радиус на некосена трева</p> <p>[11] Висина на косење</p> <p>[12] Ширина на косење</p> <p>[13] Монтирање на вреќата за собирање</p> <p>[14] Механички пренос</p> <p>[15] Брзина на движење (индикативна) до 3000 мин⁻¹</p> <p>[15] Хидростатички пренос</p> <p>[15] Брзина на движење (индикативна) до 3000 мин⁻¹</p> <p>[16] Ограничување на брзината со синџири за снег (ако дополнителната опрема е предвидена)</p> <p>[17] Димензии</p> <p>[18] Должина</p> <p>[19] Должина со вреќата (должина без вреќата)</p> <p>[20] Ширина</p> <p>[21] Ширина со дефлектор со страничен испуст (ширина без дефлектор со страничен испуст)</p> <p>[22] Висина</p> <p>[23] Код на уредот со сечивото</p> <p>[24] Капацитет на резервоарот за гориво</p> <p>[25] Допуштено оптеретување на уредот за влечење (најголема тежина во вертикала)</p> <p>[26] Допуштено оптеретување за уредот за влечење (најголема тежина за влечење)</p> <p>[27] Најголема вредност на наведнување</p> <p>[28] Ниво на акустичен притисок</p> <p>[29] Отстапување од мерењата</p> <p>[30] Измерено ниво на акустична моќност</p> <p>[31] Гарантирано ниво на акустична моќност</p> <p>[32] Ниво на вибрации на местото за управување</p> <p>[33] Ниво на вибрации на воланот</p> <p>[34] табела за соодветна комбинација на додаточите</p> <p>[34.A] задни додатоци</p> <p>[34.B] предни додатоци</p> <p>[42] додатоци достапни на барање</p> <p>[42.A1, 42.A2] Комплет за „мелење</p> <p>[42.B] Полнач за акумулаторот со издрљливоср</p> <p>[42.C] Комплет за приколна</p> <p>[42.D] Платно за покривање</p> <p>[42.E] Нкомплет за заштита на страничен испуст (<i>само за MP серија</i>)</p> <p>[42.F] Синџири за снег (18")</p> <p>[42.G] Гуми за кал/снег (18")</p> <p>[42.H] Приколна</p> <p>[42.I] Дробалка</p> <p>[42.J] Валјак за трева</p> <p>[42.K] Сечиво за снег</p> <p>[42.L] Собирач за лисија и трева (<i>само за SD серија</i>)</p> <p>* За одреден податок, проверете дали истиот е посочен на етикетата за идентификација на машината.</p>
--	--	---

<p>[1] NL - TECHNISCHE GEGEVENS</p> <p>[2] Nominaal vermogen (*)</p> <p>[3] Omwentelingen per minuut</p> <p>[4] Elektrische installatie</p> <p>[5] Voorbanden</p> <p>[6] Achterbanden</p> <p>[7] Bandenspanning vooraan</p> <p>[8] Bandenspanning achteraan</p> <p>[9] Massa (*)</p> <p>[10] Minimum straal ongemaaid gras</p> <p>[11] Maaihoogte</p> <p>[12] Maai breedte</p> <p>[13] Vermogen van de opvangzak</p> <p>[14] Mechanische aandrijving (Indicatieve) voortbewegingsnelheid bij 3000 min⁻¹</p> <p>[15] Hydrostatische aandrijving (Indicatieve) voortbewegingsnelheid bij 3000 min⁻¹</p> <p>[16] Snelheidslimiet met sneeuwkettingen (indien dit toebehoren voorzien is)</p> <p>[17] Afmetingen</p> <p>[18] Lengte</p> <p>[19] Lengte met zak (lengte zonder zak)</p> <p>[20] Breedte</p> <p>[21] Breedte met zijdelingse aflaatdeflector (Breedte zonder zijdelingse aflaatdeflector)</p> <p>[22] Hoogte</p> <p>[23] Code snij-richting</p> <p>[24] Vermogen van het brandstofreservoir</p> <p>[25] Belastinglimiet voor trekrichting (maximale verticale kracht)</p> <p>[26] Belastinglimiet voor trekrichting (maximaal gewicht dat getrokken kan worden)</p> <p>[27] Maximaal toegestane helling</p> <p>[28] Niveau geluidsdruk</p> <p>[29] Meetonzekerheid</p> <p>[30] Gemeten akoestisch vermogen</p> <p>[31] Gewaarborgd akoestisch vermogen</p> <p>[32] Niveau trillingen op de bestuurdersplaats</p> <p>[33] Niveau trillingen aan het stuur</p> <p>[34] Tabel voor de juiste combinatie van accessoires</p> <p>[34.A] Accessoires achterzijde</p> <p>[34.B] Accessoires voorzijde</p> <p>[42] Optionele accessoires</p> <p>[42.A1, 42.A2] Kit voor "mulching"</p> <p>[42.B] Batterij-oplader voor behoud</p> <p>[42.C] Kit tractie</p> <p>[42.D] Afdekzeil</p> <p>[42.E] Kit achterste aflaatbeveiliging (<i>alleen voor MP-serie</i>)</p> <p>[42.F] Sneeuwkettingen (18")</p> <p>[42.G] Modderwielen/sneeuwwielen (18")</p> <p>[42.H] Aanhangwagen</p> <p>[42.I] Verspreider</p> <p>[42.J] Grasrol</p> <p>[42.K] Sneeuwschuiver</p> <p>[42.L] Opvangervor bladeren en gras (<i>alleen voor SD-serie</i>)</p>	<p>[1] NO - TEKNISKE DATA</p> <p>[2] Nominell effekt (*)</p> <p>[3] Omdreiningar pr. minutt (*)</p> <p>[4] Elektrisk system</p> <p>[5] Fordekk</p> <p>[6] Bakdekk</p> <p>[7] Lufttrykk foran</p> <p>[8] Lufttrykk bak</p> <p>[9] Vekt (*)</p> <p>[10] Minste radius til ikke klippet gress</p> <p>[11] Klippehøyde</p> <p>[12] Klippebrede</p> <p>[13] Oppsamlerens volum</p> <p>[14] Mekanisk transmisjon</p> <p>[14] Fremdriftshastighet (ca.) ved 3 000 o/min.</p> <p>[15] Hydrostatisk transmisjon Fremdriftshastighet (ca.) ved 3 000 o/min.</p> <p>[16] Hastighetsgrense med snøkjettinger (hvis finnes)</p> <p>[17] Mål</p> <p>[18] Lengde</p> <p>[19] Lengde med oppsamler (lengde uten oppsamler)</p> <p>[20] Bredde</p> <p>[21] Bredde med deflektor for sideutkast (Bredde uten deflektor for sideutkast)</p> <p>[22] Høyde</p> <p>[23] Artikkelnnummer for klippeinnretning</p> <p>[24] Drivstofftankens volum</p> <p>[25] Belastningsgrense for hengeranordning (maks. vertikal kraft)</p> <p>[26] Belastningsgrense for hengeranordning (maks. hengervekt)</p> <p>[27] Maks. tillatt helling</p> <p>[28] Lydtrykknivå</p> <p>[29] Måleusikkerhet</p> <p>[30] Målt lyd effektnivå</p> <p>[31] Garantert lyd effektnivå</p> <p>[32] Vibrasjonsnivå ved førerplassen</p> <p>[33] Vibrasjonsnivå ved rattet</p> <p>[34] Tabell for korrekt kombinert bruk av tilbehør</p> <p>[34.A] Bakmontert tilbehør</p> <p>[34.B] Frontmontert tilbehør</p> <p>[42] Tilleggsutstyr på forespørsel</p> <p>[42.A1, 42.A2] Mulching-sett</p> <p>[42.B] Batterilader</p> <p>[42.C] Sett med tilhengerfeste</p> <p>[42.D] Presenning</p> <p>[42.E] Sett med vern for utkast bak (<i>MP-series</i>)</p> <p>[42.F] Snøkjettinger (18")</p> <p>[42.G] Gjorme-/snøhjul (18")</p> <p>[42.H] Tilhenger</p> <p>[42.I] Spreader</p> <p>[42.K] Snøplog</p> <p>[42.L] Blad- og gressoppsamler (<i>SD-series</i>)</p>	<p>[1] PL - DANE TECHNICZNE</p> <p>[2] Moc znamionowa (*)</p> <p>[3] Liczba obrotów na minutę (*)</p> <p>[4] Instalacja elektryczna</p> <p>[5] Koła przednie</p> <p>[6] Koła tylne</p> <p>[7] Ciśnienie powietrza kół przednich</p> <p>[8] Ciśnienie powietrza kół tylnych</p> <p>[9] Masa (*)</p> <p>[10] Minimalny promień nieskoszonej trawy</p> <p>[11] Wysokość koszenia</p> <p>[12] Szerokość koszenia</p> <p>[13] Pojemność pojemnika na trawę</p> <p>[14] Napęd mechaniczny Szybkość postępu (przybliżona) przy 3000 min⁻¹</p> <p>[15] Napęd hydrostatyczny Szybkość postępu (przybliżona) przy 3000 min⁻¹</p> <p>[16] Limit prędkości z łańcuchami (jeżeli przewidziane)</p> <p>[17] Wymiary</p> <p>[18] Długość</p> <p>[19] Długość z pojemnikiem (długość bez pojemnika)</p> <p>[20] Szerokość</p> <p>[21] Szerokość z deflektorem wyrzutu bocznego (Szerokość bez deflektora wyrzutu bocznego)</p> <p>[22] Wysokość</p> <p>[23] Kod agregatu tnącego</p> <p>[24] Pojemność zbiornika paliwa</p> <p>[25] Dopuszczalne obciążenie dla urządzenia ciągnącego (maksymalna siła pionowa)</p> <p>[26] Dopuszczalne obciążenie dla urządzenia ciągnącego (maksymalny holowany ciężar)</p> <p>[27] Maksymalne dopuszczalne nachylenie</p> <p>[28] Poziom ciśnienia akustycznego</p> <p>[29] Błąd pomiaru</p> <p>[30] Poziom mocy akustycznej zmierzony</p> <p>[31] Gwarantowany poziom mocy akustycznej</p> <p>[32] Poziom drgań na stanowisku kierowcy</p> <p>[33] Poziom drgań na kierownicy</p> <p>[34] Tabela właściwego łączenia akcesoriów</p> <p>[34.A] Akcesoria tylne</p> <p>[34.B] Akcesoria przednie</p> <p>[42] Akcesoria dostępne na zamówienie</p> <p>[42.A1, 42.A2] Zestaw mulczujący</p> <p>[42.B] Ładowarka akumulatora</p> <p>[42.C] Zestaw do holowania</p> <p>[42.D] Pokrowiec</p> <p>[42.E] Zestaw osłony tylnego wyrzutu trawy (<i>wyłącznie dla serii MP</i>)</p> <p>[42.F] Łańcuchy przeciwnieogowe (18")</p> <p>[42.G] Koła błotne / śnieżne (18")</p> <p>[42.H] Przyczepa</p> <p>[42.I] Rozrutnik</p> <p>[42.J] Walec do trawy</p> <p>[42.K] Plug śnieżny</p> <p>[42.L] Zbieracz do liści i trawy (<i>wyłącznie dla serii SD</i>)</p>
<p>* Voor het specifiek gegeven, verwijst men naar wat aangegeven is op het identificatie-label van de machine.</p>	<p>* For spesifikk informasjon, se referansen på maskinens identifikasjonsetikett.</p>	<p>* W celu uzyskania konkretnych danych, należy się odnieść do wskazówek zamieszczonych na tabliczce identyfikacyjnej maszyny.</p>

<p>[1] PT - DADOS TÉCNICOS</p> <p>[2] Potência nominal (*)</p> <p>[3] Rotações por minuto (*)</p> <p>[4] Instalação elétrica</p> <p>[5] Pneus dianteiros</p> <p>[6] Pneus traseiros</p> <p>[7] Pressão dos pneus dianteiros</p> <p>[8] Pressão dos pneus traseiros</p> <p>[9] Massa (*)</p> <p>[10] Raio mínimo da relva não cortada</p> <p>[11] Altura de corte</p> <p>[12] Largura de corte</p> <p>[13] Capacidade do saco de recolha</p> <p>[14] Transmissão mecânica Velocidade de avanço (indicativa) a 3000 min⁻¹</p> <p>[15] Transmissão hidrostática Velocidade de avanço (indicativa) a 3000 min⁻¹</p> <p>[16] Limite de velocidade com correntes de neve (se o acessório for previsto)</p> <p>[17] Dimensões</p> <p>[18] Comprimento</p> <p>[19] Comprimento com saco (comprimento sem saco)</p> <p>[20] Largura</p> <p>[21] Largura com deflector de descarga lateral (Largura sem deflector de descarga lateral)</p> <p>[22] Altura</p> <p>[23] Código dispositivo de corte</p> <p>[24] Capacidade do tanque de combustível</p> <p>[25] Limite de carga por dispositivo de tração (força vertical máxima)</p> <p>[26] Limite de carga por dispositivo de tração (peso máximo rebocável)</p> <p>[27] Inclinação máxima autorizada</p> <p>[28] Nivel de pressão acústica</p> <p>[29] Incerteza de medição</p> <p>[30] Nivel de potência acústica medido</p> <p>[31] Nivel de potência acústica garantido</p> <p>[32] Nivel de vibrações no local de condução</p> <p>[33] Nivel de vibrações no volante</p> <p>[34] Tabela para a correta combinação dos acessórios</p> <p>[34.A] Acessórios posteriores</p> <p>[34.B] Acessórios frontais</p> <p>[42] Acessórios a pedido</p> <p>[42.A1, 42.A2] Kit para "mulching"</p> <p>[42.B] Carregador de baterias de manutenção</p> <p>[42.C] Kit tração</p> <p>[42.D] Lona de cobertura</p> <p>[42.E] Kit proteção de descarga traseira (apenas para série MP)</p> <p>[42.F] Correntes para neve (18")</p> <p>[42.G] Rodas para lama / neve (18")</p> <p>[42.H] Reboque</p> <p>[42.I] Espalhador</p> <p>[42.J] Rolo para relva</p> <p>[42.K] Limpa-neves com lâmina</p> <p>[42.L] Recolhedor de folhas e relva (apenas para série SD)</p>	<p>[1] RO - DATE TEHNICE</p> <p>[2] Putere nominală (*)</p> <p>[3] Rotații pe minut (*)</p> <p>[4] Instalație electrică</p> <p>[5] Pneuri față</p> <p>[6] Pneuri spate</p> <p>[7] Presiune roți față</p> <p>[8] Presiune roți spate</p> <p>[9] Masă (*)</p> <p>[10] Raza minimă de iarbă netăiată</p> <p>[11] Înălțime de tăiere</p> <p>[12] Lățime de tăiere</p> <p>[13] Capacitatea sacului de colectare</p> <p>[14] Transmisie mecanică - Viteza de avans (indicativă) la 3000 min⁻¹</p> <p>[15] Transmisie hidrostatică- Viteză de avans (indicativă) la 3000 min⁻¹</p> <p>[16] Limită de viteză cu lanțuri de zăpadă (dacă acest accesoriu este prevăzut)</p> <p>[17] Dimensiuni</p> <p>[18] Lungime</p> <p>[19] Lungime cu sac (lungime fără sac)</p> <p>[20] Lățime</p> <p>[21] Lățime cu deflector de evacuare laterală (Lățime fără deflector de evacuare laterală)</p> <p>[22] Înălțime</p> <p>[23] Codul dispozitivului de tăiere</p> <p>[24] Capacitate rezervor carburant</p> <p>[25] Limita de încărcare a dispozitivului de tracțiune (forță verticală maximă)</p> <p>[26] Limita de încărcare a dispozitivului de tracțiune (greutate maximă care poate fi tractată)</p> <p>[27] Înclinația maximă admisă</p> <p>[28] Nivel de presiune acustică</p> <p>[29] Nesiguranță în măsurare</p> <p>[30] Nivel de putere acustică măsurat</p> <p>[31] Nivel de putere acustică garantat</p> <p>[32] Nivel de vibrații la locul conducătorului</p> <p>[33] Nivel de vibrații la volan</p> <p>[34] Tabel pentru combinarea corectă a accesoriilor</p> <p>[34.A] Accesorii posteriore</p> <p>[34.B] Accesorii frontale</p> <p>[42] Accesorii la cerere</p> <p>[42.A1, 42.A2] Kit pentru „mulching”</p> <p>[42.B] Încărcător de baterie de întreținere</p> <p>[42.C] Kit de remorcare</p> <p>[42.D] Prelată pentru acoperire</p> <p>[42.E] Set de protecție pentru evacuare posterioară (numai pentru seriile MP)</p> <p>[42.F] Lanțuri de zăpadă (18")</p> <p>[42.G] Roți de noroi / zăpadă (18")</p> <p>[42.H] Remorcă</p> <p>[42.I] Distribuitor</p> <p>[42.J] Rolă pentru iarbă</p> <p>[42.K] Utilaj de dezapezire cu lamă</p> <p>[42.L] Colector de frunze și iarbă (numai pentru seriile SD)</p> <p>* Pentru informația specifică, consultați datele de pe eticheta de identificare a mașinii.</p>	<p>[1] RU - ТЕХНИЧЕСКИЕ ХАРАКТЕРИСТИКИ</p> <p>[2] Номинальная мощность (*)</p> <p>[3] Число оборотов в минуту (*)</p> <p>[4] Электропроводка</p> <p>[5] Передние шины</p> <p>[6] Задние шины</p> <p>[7] Давление в передних шинах</p> <p>[8] Давление в задних шинах</p> <p>[9] Масса (*)</p> <p>[10] Минимальный радиус несеношенной травы</p> <p>[11] Высота скашиваемой травы</p> <p>[12] Ширина скашивания</p> <p>[13] Вместимость контейнера для сбора травы</p> <p>[14] Механическая трансмиссия - Скорость передвижения (ориентировочная) при 3000 мин⁻¹</p> <p>[15] Гидростатическая трансмиссия - Скорость передвижения (ориентировочная) при 3000 мин⁻¹</p> <p>[16] Предел скорости с цепями противоскольжения или предусмотрено это дополнительное оборудование)</p> <p>[17] Габариты</p> <p>[18] Длина</p> <p>[19] Длина с контейнером (длина без контейнера)</p> <p>[20] Ширина</p> <p>[21] Ширина с боковым желобом для выброса (Ширина без бокового желоба для выброса)</p> <p>[22] Высота</p> <p>[23] Код режущего приспособления</p> <p>[24] Объем топливного бака</p> <p>[25] Максимальная нагрузка, которая может быть приложена к буксировочному устройству (макс. вертикальная нагрузка)</p> <p>[26] Максимальная нагрузка, которая может быть приложена к буксировочному устройству (макс. буксиримый вес)</p> <p>[27] Допустимый максимальный наклон</p> <p>[28] Уровень звукового давления</p> <p>[29] Погрешность измерения</p> <p>[30] Измеренный уровень звуковой мощности</p> <p>[31] Гарантируемый уровень звуковой мощности</p> <p>[32] Уровень вибрации на месте водителя</p> <p>[33] Уровень вибрации на руле</p> <p>[34] таблица правильного сочетания принадлежностей – навесных орудий</p> <p>[34.A] задние навесные орудия</p> <p>[34.B] фронтальные навесные орудия</p> <p>[42] принадлежности – навесные орудия по заказу</p> <p>[42.A1, 42.A2] Комплект для мульчирования</p> <p>[42.B] поддерживающее зарядное устройство</p> <p>[42.C] Прицепное устройство</p> <p>[42.D] Защитный чехол</p> <p>[42.E] Комплект защиты заднего выброса (только для серии MP)</p> <p>[42.F] Цепи противоскольжения (18")</p> <p>[42.G] Колеса для грязи / снега (18")</p> <p>[42.H] Прицеп</p> <p>[42.I] Разбрасыватель</p> <p>[42.J] Валок для травы</p> <p>[42.K] Шнекороторный снегоочиститель</p> <p>[42.L] Сборщик травы и листьев (только для серии SD)</p>
<p>* Para o dado específico, consulte a etiqueta de identificação da máquina.</p>		<p>* Точное значение см. на идентификационном ярлыке машины</p>

<p>[1] SK - TECHNICKÉ PARAMETRE</p> <p>[2] Menovitý výkon (*)</p> <p>[3] Otáčky za minútu (*)</p> <p>[4] Elektroinštalácia</p> <p>[5] Predné pneumatiky</p> <p>[6] Zadné pneumatiky</p> <p>[7] Tlak hustenia predných pneumatík</p> <p>[8] Tlak hustenia zadných pneumatík</p> <p>[9] Hmotnosť (*)</p> <p>[10] Minimálny akčný rádius otáčania</p> <p>[11] Výška kosenia</p> <p>[12] Šírka orezávania</p> <p>[13] Kapacita zberného koša</p> <p>[14] Mechanická prevodovka - Rýchlost pohybu (približná) pri 3000 min⁻¹</p> <p>[15] Hydrostatická prevodovka Rýchlost pohybu (približná) pri 3000 min⁻¹</p> <p>[16] Hraničná rýchlosť so snehovými refazami (ak sa jedná o určené príslušenstvo)</p> <p>[17] Rozmery</p> <p>[18] Dĺžka</p> <p>[19] Dĺžka s košom (dĺžka bez koša)</p> <p>[20] Šírka</p> <p>[21] Šírka vychýľovača bočného vyhadzovania (Šírka bez vychýľovača bočného vyhadzovania)</p> <p>[22] Výška</p> <p>[23] Kód kosiaceho zariadenia</p> <p>[24] Kapacita palivovej nádržky</p> <p>[25] Maximálne zaťaženie ťažného zariadenia (max. zvisle pôsobiaca sila)</p> <p>[26] Maximálne zaťaženie ťažného zariadenia (max. hmotnosť ťahaného nákladu)</p> <p>[27] Maximálny povolený náklon</p> <p>[28] Úroveň akustického tlaku</p> <p>[29] Nepresnosť merania</p> <p>[30] Úroveň nameraného akustického výkonu</p> <p>[31] Úroveň zarúčeného akustického výkonu</p> <p>[32] Úroveň vibrácií na mieste vodiča</p> <p>[33] Úroveň vibrácií na volante</p> <p>[34] Tabuľka pre správnu kombináciu prídavných zariadení</p> <p>[34.A] Zadné prídavné zariadenia</p> <p>[34.B] Predné prídavné zariadenia</p> <p>[42] Prídavné zariadenia na požiadanie</p> <p>[42.A1, 42.A2] Súprava pre mulčovanie</p> <p>[42.B] Udrživacia nabíjacia akumulátora</p> <p>[42.C] Súprava ťažného zariadenia</p> <p>[42.D] Krycia plachta</p> <p>[42.E] Súprava ochranného krytu zadného vyhadzovania (<i>vylučne pre sériu MP</i>)</p> <p>[42.F] Snehové reťaze (18")</p> <p>[42.G] Kolesá do blata / snehu (18")</p> <p>[42.H] Príves</p> <p>[42.I] Posypávač</p> <p>[42.J] Valec na valcovanie trávy</p> <p>[42.K] Snehová radlica</p> <p>[42.L] Zberač listia a trávy (<i>vylučne pre sériu SD</i>)</p> <p>* Ohľadne uvedeného parametra vychádzajte z hodnoty uvedenej na identifikačnom štítku stroja.</p>	<p>[1] SL - TEHNIČNI PODATKI</p> <p>[2] Nazivna moč (*)</p> <p>[3] Vrtljaji na minuto (*)</p> <p>[4] Električna napeljava</p> <p>[5] Prednje pnevmatike</p> <p>[6] Zadnje pnevmatike</p> <p>[7] Tlak v prednjih pnevmatikah</p> <p>[8] Tlak v zadnjih pnevmatikah</p> <p>[9] Masa (*)</p> <p>[10] Najmanjše področje nepokošene trave</p> <p>[11] Višina košnje</p> <p>[12] Širina reza</p> <p>[13] Kapaciteta zbiralne košare</p> <p>[14] Mehanski menjalnik</p> <p>[15] Hidrostaticni menjalnik</p> <p>[16] Hitrost vožnje (približna) pri 3000 min⁻¹</p> <p>[17] Omejitve hitrosti ob montiranih snežnih verigah (če so predvidene kot oprema)</p> <p>[17] Dimenzije</p> <p>[18] Džlka</p> <p>[19] Džlka s košom (džlka bez koša)</p> <p>[20] Širina</p> <p>[21] Širina z odbijajem bočnega izmeta (širina brez odbijaja bočnega izmeta)</p> <p>[22] Višina</p> <p>[23] Šifra rezalne naprave</p> <p>[24] Prostornina rezervoarja za gorivo</p> <p>[25] Omejitve obremenitve za vlečno napravo (maksimalna vertikalna sila)</p> <p>[26] Omejitve obremenitve za vlečno napravo (maksimalna teža pri vleki)</p> <p>[27] Maksimalni dovoljen naklon</p> <p>[28] Raven zvočnega tlaka</p> <p>[29] Merilna negotovost</p> <p>[30] Izmerjena raven zvočne moči</p> <p>[31] Zajamčena raven zvočne moči</p> <p>[32] Stopnja vibracij na vozniškem sedišču</p> <p>[33] Nivo vibracij na volanu</p> <p>[34] Tabela za pravilno kombinacijo dodatnih priključkov</p> <p>[34.A] Zadnji priključki</p> <p>[34.B] Sprednji priključki</p> <p>[42] Dodatni priključki na zahtevo</p> <p>[42.A1, 42.A2] Komplet za mulčenje</p> <p>[42.B] Polnilnik akumulátorja za vzdrževanje</p> <p>[42.C] Komplet za vleko</p> <p>[42.D] Prekrivno platno</p> <p>[42.E] Komplet ščitnika zadnjega izmeta (<i>samo za MP serijo</i>)</p> <p>[42.F] Snežne verige (18")</p> <p>[42.G] Kolesa za blato / sneg (18")</p> <p>[42.H] Prikolica</p> <p>[42.I] Trosilec</p> <p>[42.J] Valj za travo</p> <p>[42.K] Snežni plug z nožem</p> <p>[42.L] Pobiralnik listja in trave (<i>samo za SD serijo</i>)</p> <p>* Za specifični podatek glej identifikacijsko nalepko stroja.</p>	<p>[1] SR - TEHNIČKI PODACI</p> <p>[2] Nazivna snaga (*)</p> <p>[3] Obrtaji u minuti (*)</p> <p>[4] Električna instalacija</p> <p>[5] Prednje gume</p> <p>[6] Zadnje gume</p> <p>[7] Pritisak vazduha u prednjim gumama</p> <p>[8] Pritisak vazduha u zadnjim gumama</p> <p>[9] Masa (*)</p> <p>[10] Minimalni poluprečnik nepokošene trave</p> <p>[11] Visina košenja</p> <p>[12] Širina košenja</p> <p>[13] Kapacitet vreće za skupljanje trave</p> <p>[14] Mehanički prenos Brzina kretanja (orijentaciono) na 3000 min⁻¹</p> <p>[15] Hidrostaticki prenos Brzina kretanja (orijentaciono) na 3000 min⁻¹</p> <p>[16] Ograničenje brzine s lancima za sneg (ukoliko su oni redviđeni kao dodatna oprema)</p> <p>[17] Dimenzije</p> <p>[18] Dužina</p> <p>[19] Dužina s vrećom (dužina bez vreće)</p> <p>[20] Širina</p> <p>[21] Širina s usmerivačem bočnog izbacivanja (Širina bez usmerivača bočnog izbacivanja)</p> <p>[22] Visina</p> <p>[23] Šifra rezne glave</p> <p>[24] Kapacitet rezervoara goriva</p> <p>[25] Granica nosivosti uređaja za vuču (maksimalna vertikalna sila)</p> <p>[26] Granica nosivosti uređaja za vuču (maksimalna težina koja sme da se vuče)</p> <p>[27] Maksimalni dozvoljen nagib</p> <p>[28] Nivo zvučnog pritiska</p> <p>[29] Merna nesigurnost</p> <p>[30] Izmereni nivo zvučne snage</p> <p>[31] Garantovani nivo zvučne snage</p> <p>[32] Nivo vibracija na mestu vozača</p> <p>[33] Nivo vibracija na volanu</p> <p>[34] Tablica za pravilno kombinovanje dodatne opreme</p> <p>[34.A] Zadnja dodatna oprema</p> <p>[34.B] Prednja dodatna oprema</p> <p>[42] Dodatna oprema na zahtev</p> <p>[42.A1, 42.A2] Komplet za malčiranje</p> <p>[42.C] Punjač akumulatora za održavanje</p> <p>[42.D] Pokrovna cerada</p> <p>[42.E] Komplet štitnika za izbacivanje otpoza-di (<i>edina za MP serija</i>)</p> <p>[42.F] Lanci za sneg (18")</p> <p>[42.G] Točkovi za blato / sneg (18")</p> <p>[42.H] Prikolica</p> <p>[42.I] Posipač</p> <p>[42.J] Valjak za travu</p> <p>[42.K] Plug za sneg z nožem</p> <p>[42.L] Plug za sneg s nožem (<i>edina za SD serija</i>)</p> <p>* Za specifični podatak, pogledajte podatke navedene na identifikacijskoj nalepnici mašine.</p>
--	---	---

<p>[1] SV - TEKNISKA SPECIFIKATIONER</p> <p>[2] Nominell effekt (*)</p> <p>[3] Varv i minuten (*)</p> <p>[4] Elanläggning</p> <p>[5] Framdäck</p> <p>[6] Backdäck</p> <p>[7] Däcktryck fram</p> <p>[8] Däcktryck bak</p> <p>[9] Vikt (*)</p> <p>[10] Minimiradie på oklippt gräs</p> <p>[11] Klipphöjd</p> <p>[12] Klippbredd</p> <p>[13] Uppsamlingspåsens kapacitet</p> <p>[14] Mekanisk transm ission Körhastighet (indikativ) vid 3 000 min⁻¹</p> <p>[15] Hydrostatisk transmission Körhastighet (indikativ) vid 3 000 min⁻¹</p> <p>[16] Hastighetsgräns med snökedjor (om tillbehör förutses)</p> <p>[17] Dimensioner</p> <p>[18] Längd</p> <p>[19] Längd med påse (längd utan påse)</p> <p>[20] Bredd</p> <p>[21] Bredd med sidotömningens riktplatta (Bredd utan sidotömningens riktplatta)</p> <p>[22] Höjd</p> <p>[23] Skärenhetens kod</p> <p>[24] Bränsletankens kapacitet</p> <p>[25] Belastningsgräns för drag (max. vertikal belastning)</p> <p>[26] Belastningsgräns för drag (max. bogser- bar vikt)</p> <p>[27] Max. tillåten lutning</p> <p>[28] Ljudtrycksnivå</p> <p>[29] Tivvel med mått</p> <p>[30] Uppmått ljudeffektnivå</p> <p>[31] Garanterad ljudeffektnivå</p> <p>[32] Vibrationsnivå på förarplatsen</p> <p>[33] Vibrationsnivå på ratten</p> <p>[34] Tabell över korrekt kombination av tillbehör</p> <p>[34.A] Bakre tillbehör</p> <p>[34.B] Främre tillbehör</p> <p>[42] Fyllvalstillbehör</p> <p>[42.A1, 42.A2] Sats för "mulching"</p> <p>[42.B] Batteriladdare för utjämningsladdning</p> <p>[42.C] Sats för bogsering</p> <p>[42.D] Presenning</p> <p>[42.E] Sats med bakre tömningsskydd (<i>endast för MP-serien</i>)</p> <p>[42.F] Snökedjor 18"</p> <p>[42.G] Hjul för lera/snö</p> <p>[42.H] Spridare</p> <p>[42.I] Släp</p> <p>[42.J] Vals för gräs</p> <p>[42.K] Snöröjare med blad</p> <p>[42.L] Blad- och grässamlare (<i>endast för SD-serien</i>)</p> <p>* För specifik information, se uppgifterna på maskinens märkplåt.</p>	<p>[1] TR - TEKNİK VERİLER</p> <p>[2] Nominal güç (*)</p> <p>[3] Dakikadaki devir sayısı (*)</p> <p>[4] Elektrik tesisi</p> <p>[5] Ön tekerlekler</p> <p>[6] Arka tekerlekler</p> <p>[7] Ön şişirme basıncı</p> <p>[8] Arka şişirme basıncı</p> <p>[9] Kütle (*)</p> <p>[10] Minimum kesilmemiş çim yarıçapı</p> <p>[11] Kesim yüksekliği</p> <p>[12] Kesim genişliği</p> <p>[13] Toplama sepeti kapasitesi</p> <p>[14] Mekanik transmisyon 3000 dak⁻¹'de ilerleme hızı (yaklaşık)</p> <p>[15] Hidrostatik transmisyon 3000 dak⁻¹'de ilerleme hızı (yaklaşık)</p> <p>[16] Kar zincirleri ile (aksesuar öngörülümüş ise) hız limiti</p> <p>[17] Ebatlar</p> <p>[18] Sepetli</p> <p>[19] Sepetli uzunluk (sepetsiz uzunluk)</p> <p>[20] Genişlik</p> <p>[21] Yandan tahliye deflektörüyle genişlik (Yan- dan tahliye deflektörü olmadan genişlik)</p> <p>[22] Yükseklik</p> <p>[23] Kesim düzeni kodu</p> <p>[24] Yakıt deposu kapasitesi</p> <p>[25] Çekme tertibatı için yük limiti (maksimum dikay kuvvet)</p> <p>[26] Çekme tertibatı için yük limiti (çekilebilir maksimum ağırlık)</p> <p>[27] İzin verilen maksimum eğim</p> <p>[28] Ses basınç seviyesi</p> <p>[29] Ölçü belirsizliği</p> <p>[30] Ölçülen ses gücü seviyesi</p> <p>[31] Garanti edilen ses gücü seviyesi</p> <p>[32] Sürücü mahalinde titreşim seviyesi</p> <p>[33] Direksiyonda titreşim seviyesi</p> <p>[34] Aksesuarların doğru kombinasyonu için tablo</p> <p>[34.A] Arka aksesuarlar</p> <p>[34.B] ön aksesuarlar</p> <p>[42] Talep üzerine aksesuarlar</p> <p>[42.A1, 42.A2] "Malçlama" Kıtı</p> <p>[42.B] Koruma batarya şarjı</p> <p>[42.C] Çeküş Kıtı</p> <p>[42.D] Kaplama Kıtı</p> <p>[42.E] Arka tahliye koruma kıtı (<i>sadece MP serisi için</i>)</p> <p>[42.F] Kar zincirleri (18")</p> <p>[42.G] Çamur / kar tekerleri (18")</p> <p>[42.H] Römork</p> <p>[42.I] Serpici</p> <p>[42.J] Çim silindiri</p> <p>[42.K] Bıçaklı kar temizleme makinesi</p> <p>[42.L] Yaprak ve çim toplayıcı (<i>sadece SD serisi için</i>)</p> <p>* Spesifik değer için, makine belirleme etike- tinde belirtilenleri referans alın</p>	
--	---	--



INDEX

1. GENERAL INFORMATION.....	2	7.7 Nuts and bolts.....	17
2. SAFETY REGULATIONS.....	2	8. EXTRAORDINARY MAINTENANCE.....	17
3. GETTING TO KNOW THE MACHINE.....	4	8.1 Safety recommendations.....	17
3.1 Description of the machine and planned use.....	4	8.2 Cutting-means assembly / cutting means	18
3.2 Safety signs.....	5	8.3 Replacing of front / rear wheels.....	18
3.3 Identification label.....	6	8.4 Electronic circuit board.....	19
3.4 Main components.....	6	8.5 Replacing a fuse.....	19
4. ASSEMBLY.....	6	8.6 Replacing bulbs.....	19
4.1 Assembly components.....	6	8.7 Rear axle.....	19
4.2 Steering wheel assembly.....	7	9. STORING THE MACHINE.....	19
4.3 Seat assembly.....	7	10. HANDLING AND TRANSPORTATION.....	20
4.4 Mounting and connecting the battery.....	7	11. ASSISTANCE AND REPAIRS.....	20
4.5 Mounting the rear bumper.....	7	12. WARRANTY COVERAGE.....	20
4.6 Side discharge chute assembly (for models with side discharge only).....	7	13. MAINTENANCE TABLE.....	21
4.7 Mounting the cutting-means assembly side reinforcements (for side discharge models only, if foreseen).....	8	14. PROBLEM IDENTIFICATION.....	22
4.8 Rear plate assembly and completion (for rear collection models only).....	8	15. ATTACHMENTS.....	25
5. CONTROLS.....	8	15.1 "Mulching" kit.....	25
5.1 Key ignition switch.....	8	15.2 Maintenance battery charger.....	25
5.2 Throttle control.....	8	15.3 Towing kit.....	25
5.3 Parking brake lever.....	9	15.4 Canvas cover.....	25
5.4 Clutch / brake pedal (mechanical drive)	9	15.5 Rear discharge guard kit.....	25
5.5 Speed change lever (mechanical drive)	9	15.6 18" Snow chains.....	25
5.6 Brake pedal (hydrostatic drive).....	9	15.7 18" Mud / snow wheels.....	25
5.7 Hydrostatic transmission disengagement lever (hydrostatic transmission).....	9	15.8 Trailer.....	25
5.8 Cutting means engage and disengage functions.....	10	15.9 Sprinkler.....	25
5.9 Reverse gear cutting consent button.....	10	15.10 Grass roller.....	25
5.10 Cutting height adjuster lever.....	10	15.11 Snow blade.....	25
5.11 Acoustic alarm indicator light and device (for rear collection models only).....	10	15.12 Leaf and grass collector.....	25
5.12 Grass catcher tipping lever (if foreseen, for rear collection models only).....	10		
6. USING THE MACHINE.....	10		
6.1 Preparation.....	10		
6.2 Safety checks.....	11		
6.3 Using on slopes.....	12		
6.4 Startup.....	12		
6.5 Operation.....	12		
6.6 Stop.....	14		
6.7 After operation.....	14		
7. ROUTINE MAINTENANCE.....	15		
7.1 General information.....	15		
7.2 Refuelling / emptying the fuel tank.....	15		
7.3 Check, top up, draining of engine oil.....	15		
7.4 Anti-chipping wheels.....	16		
7.5 Cleaning.....	16		
7.6 Battery.....	17		

1. GENERAL INFORMATION

1.1 HOW TO READ THE MANUAL

Some paragraphs in the manual contain important information regarding safety and operation and are emphasized in this manner:

NOTE or **IMPORTANT** *these give details or further information on what has already been said, and aim to prevent damage to the machine.*

The  symbol highlights danger. Non-compliance with the warning could lead to personal and/or third party injury and or damage.

The paragraphs highlighted in a square with grey spots indicate the optional characteristics not on all models documented in this manual. Check if the characteristic is on this model.

Whenever reference is made to a position on the machine "front", "back", "left" or "right" hand side, this refers to the operator's working position.

1.2 REFERENCES

1.2.1 Figures

The figures in these instructions for use are numbered 1, 2, 3, etc. Components shown in the figures are marked A, B, C, etc.

A reference to component C in figure 2 is written: "See fig. 2.C" or simply "(Fig. 2.C)". The figures are given as a guide only. The actual parts may vary from those shown.

1.2.2 Titles

The manual is divided into chapters and paragraphs. The title of paragraph "2.1 Training" is a sub-title of "2. Safety regulations". References to titles or paragraphs are marked with the abbreviation chap. or par. and the relevant number. Example: "chap. 2" or "par. 2.1"

2. SAFETY REGULATIONS

2.1 TRAINING

 **Become acquainted with the controls and the proper use of the machine. Learn**

how to stop the engine quickly. Failure to follow the warnings and instructions may result in fire and/or serious injury.

- Never allow children or persons unfamiliar with these instructions to use the machine. Local regulations may restrict the age of the operator.
- Never use the machine if the user is tired or unwell, or has taken medicine, drugs, alcohol or any substances which may slow his reflexes and compromise his judgement.
- Do not allow children or other passengers to ride on the machine.
- Bear in mind that the operator or user is responsible for accidents or unexpected events occurring to other people or their property. It is the user's responsibility to assess the potential risk of the area where work is to be carried out, and to take all the necessary precautions to ensure his own safety and that of others, particularly on slopes or rough, slippery and unstable ground.
- If the machine is sold or lent to others, make sure that the operator looks over the user instructions contained in this manual.

2.2 PREPARATION

Personal Protective Equipment (PPE)

- Always wear suitable work attire, hard-wearing safety footwear with non-slip soles and long trousers. Do not operate the machine when barefoot or wearing open sandals. Wear hearing protection devices.
- Never wear scarves, shirts, necklaces, bracelets, clothing with flowing parts, laces or ties or any hanging or flapping accessory that could catch in the machine or in any objects or materials in the work area.
- Tie your hair back if it is long.

Work area/Machine

- Thoroughly inspect the entire work area and remove anything that could be thrown by the machine or damage the cutting means/rotating units (stones, branches, iron wire, bones, etc.).

Internal combustion engines: fuel

 **DANGER!** The fuel is highly flammable.

- Keep the fuel in approved containers, in a safe place, away from any naked lights or heat sources.
- Keep the containers and storage area free of grass cuttings, leaves, or excessive grease.
- Keep the containers out of the reach of children.

- Do not smoke when filling up with fuel or when handling the fuel.
- Use a funnel to top up with fuel only in the open air.
- Do not inhale fuel fumes.
- Never remove the tank cap or add fuel while the engine is running or when the engine is hot.
- Open the fuel tank slowly to allow the pressure inside to decrease gradually.
- Do not approach the tank opening with a naked flame to check its contents.
- If you have spilled some fuel, do not attempt to start the engine but move the machine away from the area of spillage and avoid creating any source of ignition until the fuel has evaporated and fuel vapours have dissipated.
- Immediately clean up all traces of fuel spilt on the machine or on the ground.
- Replace caps of all fuel tanks and containers securely.
- Never start the machine in the same place in which you refilled it with fuel; the engine must be started in an area at least 3 metres from where you refuelled.
- If fuel is spilt on clothing, change clothing before starting the engine.
- Pay attention on sloping ground which requires particular care to prevent overturning or loss of control of the machine. The main reasons for loss of control are:
 - Insufficient wheel grip
 - Excessive speed
 - Inadequate braking
 - Type of machine unsuitable for its task
 - Lack of awareness of the effect of ground conditions, especially slopes
 - Incorrect use as a towing machine.

Behaviour

- When working behind the wheel, do not become distracted and maintain the required level of concentration.
- Exercise caution when reversing or moving backwards. Look behind you to make sure there are no obstacles before and during operations in reverse gear.
- Use care when pulling loads or using heavy equipment:
 - Use approved drawbar hitch points only when towing;
 - Do not turn sharply. Take care when reversing;
 - Use counterweight(s) or wheel weights whenever advised in the instructions manual.
- Pay attention when using the grass catcher and attachments that can alter the stability of the machine, especially on slopes.
- Always keep hands and feet away from the cutting means, when starting and when using the machine.
- Attention: the cutting means will continue to rotate for a few seconds after disengagement or after you have switched off the engine.
- Pay attention to cutting-means assemblies with more than one cutting means, as a rotating cutting means can trigger the rotation of the others,
- Keep away from the discharge opening.
- Do not touch the engine parts which heat up during use. Burns hazard.
- To avoid the risk of fire, do not leave the machine standing in high grass with the engine running.

 If something breaks or an accident occurs during work, turn off the engine immediately and move the machine away to prevent further damage; if an accident occurs with injuries or third parties are injured, carry out the first aid measures most suitable for the situation immediately and contact the medical authorities for any necessary health care. Carefully remove any debris which could cause damage or injury to persons or animals if ignored.

2.3 DURING OPERATION

Work Area

- Do not operate the engine in a confined space where dangerous carbon monoxide fumes can develop. All starting operations have to be effected in an open or well ventilated area. Always remember that exhaust gases are toxic!
- When starting up the machine, do not direct the silencer and therefore the exhaust fumes towards flammable materials.
- Do not use the machine in environments at risk of explosion, in the presence of flammable liquids, gas or powder. Electrical contacts and mechanical friction can generate sparks that can ignite the powder or vapours.
- Work only in daylight or with good artificial light in good visibility conditions.
- Keep persons, children and animals away from the working area. Instruct another adult to supervise any children in the vicinity.
- Avoid working with wet grass, in the rain and when there is a risk of a thunderstorm, especially lightning.
- Pay careful attention to uneven ground (hills, dips), slopes, hidden hazards and obstacles than could limit visibility.
- Be very careful near ravines, ditches or embankments. The machine could overturn if a wheel slides over the edge or if the earth gives way.

Use limitations

- Never operate the machine with guards damaged, missing or incorrectly assembled (grass catcher, side discharge guards rear discharge guards)
- Don't use the machine if the attachments/tools are not installed in their seats.
- Never disengage, deactivate, remove or tamper with the safety systems/microswitches installed.
- Do not strain the machine too much and do not use a small machine for heavy-duty work. If you use the right machine, you will reduce the risk of hazards and improve the quality of your work.
- The machine has not been approved for use on public roads. It must be used (as indicated by the highway code) in private areas closed to traffic.

2.4 MAINTENANCE, STORAGE

Ensure regular maintenance and correct storage to maintain machine safety and high performance levels.

Maintenance

- Never use the machine with worn or damaged parts. Faulty or worn-out parts must always be replaced and never repaired.
- To reduce the risk of fire, regularly check the machine for oil and/or fuel leaks.
- Be careful during adjustment of the machine to prevent entrapment of the fingers between moving parts of the cutting means and fixed parts of the machine.

 The noise and vibration levels shown in these instructions are the maximum levels for use of the machine. The use of an unbalanced cutting element, the excessive speed of movement, or the absence of maintenance have a significant influence on noise emissions and vibrations. Consequently, it is necessary to take preventive steps to eliminate possible damage due to high levels of noise and stress from vibration. Maintain the machine well, wear ear protection devices, and take breaks while working.

Storage

- Do not store the machine with fuel in the tank in an area where fuel vapours could reach a naked light, a spark or a strong heat source.
- To reduce fire risks, do not leave containers with debris inside a room.

2.5 ENVIRONMENTAL PROTECTION

Safeguarding the environment must be a relevant and priority aspect of machine use, of benefit to the community and the environment we live in.

- Avoid being a disturbance to the neighbourhood. Use this machine at reasonable times of the day only (not early morning or late evening when the noise could cause disturbance).
- Adhere strictly to the local regulations governing the disposal of packaging, oil, fuel, filters, damaged parts or any other element which may have an impact on the environment; this waste should not be disposed of along with standard household waste, but must be disposed of separately and sent to special waste disposal facilities for handling and recycling.
- Scrupulously comply with local regulations for the disposal of waste materials
- When the machine is withdrawn from service, do not dump it in the environment, but take it to a waste disposal facility in accordance with the local regulations in force.

3. GETTING TO KNOW THE MACHINE

3.1 DESCRIPTION OF THE MACHINE AND PLANNED USE

This machine is a ride-on lawn mower with seated operator.

The machine is equipped with an engine which drives a cutting unit protected by a casing, as well as a transmission unit that moves the machine. This machine is fitted with rear traction.

The rear axle can also be fitted with:

- mechanical drive with 5 forward gears and 1 reverse gear.
- hydrostatic drive with infinite ("Hydro") forward and reverse gears.

The operator is able to operate the machine and use the main controls, always seated in the operator's position.

The safety devices installed on the machine will disengage the engine and cutting means in a couple of seconds (par. 6.2.2).

3.1.1 Intended use

This machine was designed and built to cut grass.

Generally speaking this machine can:

- MP 84 / MP 98 Series can:

1. mow the grass and collect it in the grass catcher
 2. mow the grass and discharge it on the ground from the rear section
 3. mow, chop and deposit the grass on the ground (mulching effect).
- SD 98 / 108 Series can:
4. mow the grass and discharge it from the side
 5. mow, chop and deposit the grass on the ground (mulching effect).

The use of special attachments provided for by the Manufacturer as original equipment or which may be purchased separately, allows this work to be done in various operating modes, illustrated in this manual or the instructions that accompany the single attachments. Likewise, the intended use can be extended to include other functions by applying supplementary attachments (if provided for by the Manufacturer), abiding by the restrictions and conditions indicated in the instructions accompanying the attachment.

3.1.2 Improper use

- Any other usage not in keeping with the afore-mentioned ones may be hazardous and harm persons and/or damage things. Examples of improper use may include, but are not limited to:
 - allowing children, animals or other passengers to ride on the machine as they could fall off and injure themselves or compromise safe driving by the operator;
 - towing or pushing loads without the use of the specified attachment for towing;
 - using the machine for riding over unstable, slippery, icy, stony, rough, marshy ground or puddles that do not allow the consistency of the ground to be assessed;
 - using the cutting means on surfaces other than grass;
 - using of the machine for leaf or debris collection.

IMPORTANT *Improper use of the machine will invalidate the warranty, relieve the Manufacturer from all liabilities, and the user will consequently be liable for all and any damage or injury to himself or others.*

3.1.3 User types

This machine is intended for use by consumers, i.e. non-professional operators. The machine is intended for "DIY" use only.

IMPORTANT *The machine must be used by one operator.*

3.2 SAFETY SIGNS

The machine has various symbols on it (fig. 2). They are used to remind the operator of the behaviour to follow to use it with the necessary attention and caution. Meaning of symbols:



Warning: Read the instructions before operating the machine.



Warning: Disconnect the key and read the instructions before carrying out any maintenance or repair work.



Danger! Ejected objects: Do not operate without either the rear discharge guard or the grass catcher being in place. (for models with rear collection only)



Danger! Ejected objects: do not operate without side discharge chute in place. (for models with side discharge only)



Danger! Ejected objects: Keep bystanders at a safe distance



Danger! Machine rollover: Do not use this machine on slopes greater than 10°



Danger! Dismemberment: Make sure that children stay clear of the machine all the time when engine is running



Cutting hazard. Cutting means in motion. Do not put hands or feet near or under the opening of the cutting means housing.



Warning! Keep away from hot surfaces.

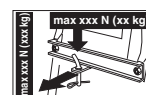

When using the towing kit, do not exceed the recommended loads stated on the label and follow the safety instructions.

IMPORTANT Any damaged or illegible decals must be replaced. Order replacement decals from an authorised assistance centre.

3.3 IDENTIFICATION LABEL

The identification label holds the following data (fig. 1):

1. Acoustic power level
2. CE Conformity marking
3. Year of manufacture
4. Operating engine power and speed
5. Machine model
6. Type of machine
7. Serial number
8. Weight in kg
9. Name and address of Manufacturer
10. Type of transmission
11. Article code

Write the identification data of the machine in the specific space on the label on the back of the cover page.

IMPORTANT Quote the information on the product identification label whenever you contact an authorized service workshop.

IMPORTANT The example of the Declaration of Conformity is provided on the last pages of the manual.

3.4 MAIN COMPONENTS

The machine is composed of a series of main components that have the following functions (fig.1):

- A. Cutting-means assembly:** this is the assembly comprising the casing that houses the rotating cutting means, and the cutting means.
- B. Cutting means:** these are what cut the grass; the fins at the ends help convey the cut grass towards the discharge chute.
- C. Side discharge chute:** a safety device to prevent objects drawn up by the cutting means from being hurled by the machine (for side discharge models only).
- D. Discharge chute: this is the part connecting the cutting-means assembly to the grass catcher** (for models with rear collector only).
- E. Grass catcher:** as well as collecting the grass cuttings, this is also a safety element that stops any objects drawn up by the cutting devices from being hurled away from the machine (for rear collection models only).

- F. Rear discharge guard** (available upon request): this can be fitted in place of the grass catcher and prevents objects from being drawn up by the cutting means and hurled away from the machine. (for rear collection models only).
- G. Driving seat:** this is where the machine operator sits. It has a sensor connected to safety devices for detecting the presence of the operator.
- H. Battery:** provides the energy for starting the engine. Its specifications and regulations for use are described in a specific manual.
- I. Engine:** this moves the cutting means and drives the wheels. Its specifications and regulations for use are described in a specific manual.
- J. Front bumper:** this protects the front section of the machine.
- K. Steering wheel:** turns the front wheels.

4. ASSEMBLY

 **The safety regulations to follow are described in chap. 2. Strictly comply with these instructions to avoid serious risks or hazards.**

For storage and transport purposes, some components of the machine are not installed in the factory and have to be assembled after unpacking. Follow the instructions below.

 **Unpacking and completing the assembly should be done on a flat and stable surface, with enough space for machine handling and its packaging, always making use of suitable equipment. Do not use the machine until all the indications provided in the "ASSEMBLY" section have been carried out.**

4.1 ASSEMBLY COMPONENTS

The packaging holds the components needed for assembly as listed in the table below:

	Description
1	Steering wheel
2	Dashboard cover and steering wheel assembly parts
3	Driving seat
4	Battery
5	Front bumpers
6	Anti-chipping wheels
7	Grass catcher with relative assembly screws and instructions (for models with rear collection only)

8	Lower part of the rear plate, the grass catcher brackets and attachments necessary for completing and assembly (<i>for rear collection models only</i>)
9	Side discharge chute (<i>for models with side discharge only</i>)
10	Cutting-means assembly side reinforcements (<i>for side discharge models only, if foreseen</i>).
11	Envelope containing: - the instruction manuals and documents - driving seat assembly screws - side discharge chute assembly fittings (<i>for models with side discharge only</i>) - the connection screws for the battery cables - 2 starter keys - 1 spare 10 A fuse

4.1.1 Unpacking

1. Cautiously open the packaging, paying attention not to lose components.
2. Consult the documentation in the box, including these instructions.
3. Remove all the unassembled parts from the box.
4. Remove the machine from the packaging taking the following precautions:
 - move the cutting-means assembly to its maximum height (par. 5.10) to protect it against damage when the machine is lifted off the base pallet;
 - Lift the machine off the base pallet.

For hydrostatic drive models, move the rear drive release lever to the locked position (par. 5.13).

4.2 STEERING WHEEL ASSEMBLY

1. Put the machine on a flat surface and straighten the front wheels.
2. Mount the hub (fig. 3.A) on the shaft (fig. 3.B), making sure that the plug (fig. 3.C) is correctly fitted into the hub seat.
3. Fit the dashboard cover (fig. 3.D) clicking the seven fasteners into place.
4. Fit the steering wheel (fig. 3.E) onto the hub (fig. 3.A) with the spokes directed towards the seat.
- 5a. **For type "I" steering wheel only**
- Fit the spacer (fig. 3.F) and fasten the steering wheel in place using the screws supplied (fig. 3.G) in the indicated order.
- 5b. **For type "II" steering wheel only** - Fasten the steering wheel in place using the screws (fig. 3.F, 3.G) supplied, in the indicated order.

6. Fit the steering wheel cover (fig. 3.H) by clicking the fasteners into place.

4.3 SEAT ASSEMBLY

Fit the seat (fig. 4.A) onto the plate (fig. 4.B) using the screws (fig. 4.C).

4.4 MOUNTING AND CONNECTING THE BATTERY

The battery (fig. 5.A) is housed under the seat and secured by a spring (fig. 5.B).

1. First connect the red wire (fig. 5.C) to the positive pole (+) and then the black wire (fig. 5.D) to the negative pole (-), using the screws supplied as shown.
2. Apply silicone grease to the terminals and check that the protective cap for the red wire (fig. 5.E) is in place.

IMPORTANT *Always fully charge the battery according to the instructions in the battery booklet.*

IMPORTANT *To prevent the safety device in the electronic circuit board from cutting in, never start the engine until the battery is fully charged!*

4.5 MOUNTING THE REAR BUMPER

- 1a. **For type "I" bumpers only** - Mount the front bumper (fig. 6A) on the bottom of the frame (fig. 6.B) using the four screws (fig. 6.C).
- 1b. **For type "II" bumpers only**
 1. Fit the two brackets (fig. 6.A) and (fig. 6.B) to the bottom of the frame (fig. 6.C) following the direction of assembly indicated in the figure: R= right; L= left.
 2. fully tighten the screws (fig. 6.D).
 3. Attach the front bumper (fig. 6.E) to the brackets (fig. 6.A) and (fig. 6.B) using the screws (fig. 6.F) and nuts (fig. 6.G).

4.6 SIDE DISCHARGE CHUTE ASSEMBLY (FOR MODELS WITH SIDE DISCHARGE ONLY)

1. From the inside of the side discharge chute (fig. 7.A), fit the spring (fig. 7.B) by inserting the terminal (fig. 7.B.1) into the hole and turning it so that both the spring (fig. 7.B) and the terminal (fig. 7.B.2) are securely positioned in their seatings.
2. Position the side discharge chute (fig. 7.A) in line with the cutting-means assembly brackets (fig. 7.C). Using a screwdriver, turn the second terminal

- (fig. 7.B.2) of the spring (fig. 7.B) to bring it outside the side discharge chute.
3. Fit the pin (fig. 7.D) in the holes on the brackets (fig. 7.C) and on the side discharge chute, so that it passes through the coils of the spring (fig. 7.B) and the drilled end comes out of the inner most bracket.
 4. Insert the cotter pin (fig. 7.E) in the pin (fig. 7.D) hole (fig. D.1) and rotate the pin until it is possible to bend the two ends (fig. 7.E.1) of the cotter pin, (with the aid of a pair of pliers), so it cannot slide out and cause the pin to fall out (fig. 7.D).

⚠ Check that the spring works correctly and keep the side discharge chute securely lowered. Make sure that the pin is fitted properly to prevent it from falling out accidentally.

IMPORTANT For models with optional side unloading: make sure that the side unloading guard (Fig. 13.A) is lowered and locked by the safety lever (Fig. 13.B).

IMPORTANT Before disassembling or servicing the deflector, always push the safety lever (Fig. 14.B) and lift the side unloading guard (Fig. 14.A) to allow disassembly.

NOTE To remove the deflector, perform assembly steps in reverse order.

4.7 MOUNTING THE CUTTING-MEANS ASSEMBLY SIDE REINFORCEMENTS (FOR SIDE DISCHARGE MODELS ONLY, IF FORESEEN).

Complete the mounting of the cutting-means assembly by fitting the side reinforcements on the cutting-means assembly profile using the screws supplied (fig. 8)

4.8 REAR PLATE ASSEMBLY AND COMPLETION (FOR REAR COLLECTION MODELS ONLY)

1. Assemble the two lower brackets (fig. 9.A) and (fig. 9.B), following the assembly direction as shown in the illustration, and fasten them with the screws (fig.9.C) and nuts (fig. 9.D), tightening them completely.
2. Remove the two screws (fig. 9.H), which will be used later.





3. Assemble the lower part (fig. 9.E) of the rear plate and fasten it to the lower brackets with the screws (fig. 9.F) and bolts (fig. 9.G), without tightening them completely.
4. Finish fastening the lower part (fig. 9.E) of the rear plate, completely tightening the two central screws (fig. 9.H) that you previously removed and the four upper screws (fig.9.I)
5. Fully tighten the two bottom nuts (fig. 9.G).
6. Insert the lever (fig. 9.J) of the “grass catcher full” indicator into its seat (fig. 9.K) and push it down until you hear a click.
7. Assemble the two grass catcher brackets (fig. 9.L) and (fig. 9.M), following the assembly direction as shown in the illustration, and fasten them with the screws (fig. 9.N) and snap washers (fig. 9.O), tightening them firmly.

5. CONTROLS

5.1 KEY IGNITION SWITCH

The key turns the machine and headlamps (if fitted) On and Off.

It has four different positions (fig. 10.A):

1. **Stop position.** The machine turns off immediately. 
2. **Headlights On position (if fitted);** After turning the engine on, turn the lights on by turning the key to this position. To switch them off, turn the key to On. 
3. **On position.** All services are enabled.. 
4. **Start position.** Switch on the starter motor to start the machine. If you release the key on start it will automatically return to On. 

5.2 THROTTLE CONTROL

Regulates the engine's r.p.m.

There are two types of throttle control according to the engine type:

- A. **Type “I” with separate Choke command** (Fig. 10.E + Fig. 10.E.1)
- B. **Type “II”** (Fig. 10.E)

The positions indicated correspond to:



- 1. Choke Command - Cold start.** Used to turn on the engine when cold. The «CHOKE» position enriches the mixture so it must only be used for the time necessary for cold starts.



- 1. Maximum engine speed.** To be used always when starting the machine, while it is On and during grass cutting operations.
- 2. Minimum engine speed.** Used when the machine is sufficiently warm during stationary periods of operation.



NOTE When moving from one area to another, put the lever in a position between «tortoise» and «hare».

5.3 PARKING BRAKE LEVER

This lever stops the machine from moving when it has been parked.

This lever has two positions (fig. 10.D), corresponding to:



- 1. Brake disengaged.** Press the pedal to disengage the parking brake (fig. 10.1). The lever returns to the brake disengaged position.



- 2. Brake engaged.** Press the pedal all the way down to engage the parking brake (fig. 10.1) and shift the lever to brake engaged position. When you take your foot off the pedal it will be blocked in the lowered position.

5.4 CLUTCH / BRAKE PEDAL (MECHANICAL DRIVE)

This pedal has a double function (fig. 10.1):



- during the first part of its travel it acts as a clutch, engaging and disengaging drive to the wheels.
- in the second part it works the brake on the rear wheels.

IMPORTANT Do not keep the pedal half way between clutch engagement or disengagement, as this can cause overheating and damage the transmission belt.

NOTE When the machine is in movement, keep your foot off the pedal.

5.5 SPEED CHANGE LEVER (MECHANICAL DRIVE)

This lever has seven positions (fig. 10.K):

1

- 1. 5 forward gears**

2

3

4

5

N

- 2. Neutral «N»**

R

- 3. Reverse «R»**

⚠ Reverse must only be engaged when the machine has stopped.

To change gear, press the pedal halfway down (Fig. 10.1) and move the lever according to the indications on the label.

5.6 BRAKE PEDAL (HYDROSTATIC DRIVE)



This pedal works the brake on the rear wheels (fig. 10.I)

5.7 HYDROSTATIC TRANSMISSION DISENGAGEMENT LEVER (HYDROSTATIC TRANSMISSION)

This lever has two positions, as shown on the plate (fig. 10.L):



- 1. Drive engaged :** for all uses, when moving and during cutting.



- 2. Drive disengaged :** this makes it much easier to move the machine by hand, with the engine turned off.

IMPORTANT To avoid damaging the transmission unit, this operation must be carried out only when the engine has stopped with the pedal (fig. 10.J) at neutral position.

5.8 CUTTING MEANS ENGAGE AND DISENGAGE FUNCTIONS

The mushroom switch allows you to engage the cutting means using an electromagnetic clutch (fig. 10.B):



1. **Cutting means engaged.**
Mushroom switch pulled



2. **Cutting means disengaged.**
Mushroom switch engaged.
 - On disengaging the cutting means, a brake is simultaneously activated which stops their rotation within a few seconds.

NOTE *If you engage the cutting means without taking the necessary safety precautions, the engine shuts down and cannot be restarted (see par. 6.2.2)*

5.9 REVERSE GEAR CUTTING CONSENT BUTTON



By pressing and holding this button (fig. 10.F), it is possible to switch to reverse gear with the cutting means engaged without causing the engine to stop.

5.10 CUTTING HEIGHT ADJUSTER LEVER

Use this lever to raise and lower the cutting-means assembly to one of the 7 different cutting heights (fig. 10.G).



The seven positions for this lever, shown as «1» to «7» on the label, correspond to various cutting heights between 3 and 8 cm.



To go from one position to another, move the lever sideways and put it back in one of the stop notches.



5.11 ACOUSTIC ALARM INDICATOR LIGHT AND DEVICE (FOR REAR COLLECTION MODELS ONLY)

- This light (fig. 10.C) comes on when the key (fig. 10.A) is in the "ON" position and stays on while the machine is running.

- When it flashes, it means that it is not ready to be started (see par. 6.2.2).
- The sound warning signals that the grass catcher is full (see par. 6.5.5).

5.12 GRASS CATCHER TIPPING LEVER (IF FORESEEN, FOR REAR COLLECTION MODELS ONLY)

This pull-out lever tips and empties the grass catcher. This means less work for the operator (fig. 10.H).

6. USING THE MACHINE

⚠ *The safety regulations to follow are described in chap. 2. Strictly comply with these instructions to avoid serious risks or hazards.*

6.1 PREPARATION

Before starting to mow, it is necessary to carry out several checks and operations to ensure you can work efficiently and in maximum safety.

6.1.1 Filling with oil and fuel

IMPORTANT *The machine is supplied without engine oil or fuel.*

Before using the machine check for fuel and the oil level (par. 7.2, par. 7.3). For refuelling and oil top-up methods and precautions follow the instructions given in (par. 7.2, par. 7.3) and in the engine handbook.

6.1.2 Seat adjustment

To change the seat position, loosen the four fixing bolts (fig. 11.A) and slide it along the slots. Once you have found the right position, tighten the four screws (fig. 11.A) thoroughly.

6.1.3 Tyre pressure

Having the right tyre pressure is the main condition for ensuring that the cutting-means assembly is horizontal and mows evenly.

1. Unscrew the valve caps
2. Connect a compressed air line with a gauge to the valves (fig. 12)
3. Adjust the pressure according to the values indicated in the "Technical Data" chart.

6.1.4 Preparing the machine before starting work

NOTE This machine can be used to mow lawns in a number of different ways; before starting work, prepare the machine based on how the lawn is to be mowed.

a. Prepare the machine for side cutting and discharge of the grass onto the floor (for models with side discharge only)

- Always make sure that the spring inside the deflector (Fig. 13.A) and the safety lever (Fig. 13.B) operate correctly, holding it firmly in the lowered position.

b. Preparation for grass cutting and collection in the grass catcher (for rear collection models only)

- Fasten the grass catcher (fig. 14.A) onto the supports (fig. 14.B) and centre it up with the rear plate. Centring is ensured by using the right bracket as lateral support.
- Make sure that the lower pipe of the grass catcher opening is attached to the pawl (fig. 14.C).

c. Prepare the machine for rear cutting and discharge of the grass onto the floor (for models with rear collection only)

- If you decide to work without the grass catcher, a rear discharge guard kit (fig. 15; chap. 15.5) is available upon request. This has to be attached to the rear plate as indicated in the instructions.

d. Preparation for mowing and mulching of grass

- If you decide to mow the grass, mulching it and leaving it on the grass, a "mulching" kit is available upon request (chap. 15.1). This has to be attached to the rear plate as indicated in the instructions.

6.1.5 Positioning the anti-scalp wheels

The anti-chipping wheels are used to reduce the risk of tearing up sections of lawn, which can occur when the edge of the cutting-means assembly drags over irregular ground. Position the wheels as indicated (par. 7.4).

6.2 SAFETY CHECKS

Run the following safety checks and check that the results correspond to those outlined on the tables.

 **Always carry out the safety checks before use.**

6.2.1 General safety check

Object	Result
Battery	No damage to the casing, cover or terminals
Rear discharge guard, grass catcher	Good condition. No damage. Properly installed.
Side discharge guard, suction grid	Good condition. No damage. Properly installed.
Fuel lines and connections.	No leaks.
Electrical cables.	All insulation intact. No mechanical damage.
Oil lines	No leaks. No damage.
Drive the machine forwards and backwards, shift to neutral / release the drive pedal (par. 5.5; par. 5.7)	The machine slows down and stops
Press the brake pedal (par. 5.4; par. 5.6)	The machine stops
Test driving	No abnormal vibrations. No abnormal sound
Safety devices	Proceed as indicated in par. 6.2.2

6.2.2 Control of safety devices

The safety devices work in two ways:

- A.** they prevent the engine from starting if all the safety requirements have not been met;
- B.** by stopping the engine if even just one of the safety requirements is lacking.

Action	Result
1. gear in "neutral"; 2. cutting means disengaged; 3. operator seated.	The engine starts
the operator leaves his seat	The engine stops
the grass catcher is lifted or the rear discharge guard removed without disengaging the cutting means (for rear collection models only)	The engine stops
the parking brake is engaged without disengaging the cutting means	The engine stops

Action	Result
the speed change is activated or the drive pedal with the parking brake engaged	The engine stops
the reverse gear is engaged with the cutting means engaged, without pressing the consent button (par. 5.9)	The engine stops

⚠ *If any of the results fails to match the indications provided in the tables, do not use the machine! Contact a service centre to have it checked and repaired if necessary.*

IMPORTANT *Always bear in mind that the safety devices prevent the engine from starting if safety requirements have not been met. In these cases, once the start consent has been reinstated, the ignition key (fig. 10.A) must first be turned back to Off before the engine can be restarted.*

6.3 USING ON SLOPES

Comply with the limits indicated in the "Technical Data" Tables ad in "fig. 18" regardless of the mowing direction.

Remember there is no such thing as a "safe" slope. Driving on grass slopes requires particular care. To prevent overturning or loss of control over the machine:

- Never mow across the face of the slope. Lawns on a slope have to be mowed moving up and down and never across them. When changing direction, take great care that the wheels facing the slope do not hit any obstacles (such as stones, branches, roots, etc.) that may cause the machine to slide sideways, tip over or make you lose control.
- Do not stop or start suddenly when going up or downhill;
- Shift to drive gear very gently paying particular attention to prevent the machine from tipping up.
- Reduce speed:
 - before changing direction and during tight turns
 - before facing a slope, particularly downhill
- Never switch to reverse gear to decrease speed when going downhill: this could cause loss of control of the machine, especially on slippery ground.
- Always engage the parking brake before leaving the machine at a standstill and unattended.

• **For models with mechanical drive**
only Never ride the machine on slopes in neutral or with the clutch out!
 Always shift into a low gear before leaving the machine at a standstill and unattended.

• **For models with hydrostatic drive**
only: Drive down slopes with your foot off the drive pedal to use the braking effect of the hydrostatic transmission when the transmission is not engaged.

6.4 STARTUP

1. Open the fuel tap (fig. 19.A) (if provided).
2. Sit in the operator's position.
3. Put the drive into neutral («N») (par. 5.5; par. 5.7).
4. Disengage the cutting means (par. 5.8).
5. Engage the parking brake (par. 5.3).
6. Shift the throttle control to maximum "hare" speed position (par. 5.2).
7. **If cold starting:** engage the choke (par. 5.2 / par. 5.2.1)
8. Insert the ignition key and turn to On to make electrical contact, then turn it to Start to start the engine.
9. Release the ignition key once the engine has started.
10. **If cold starting:** as soon as the engine ticks over regularly:
 - 10a. Disengage the choke (par. 5.2 type "II"), shift the throttle control to maximum "hare" speed position.
 - 10b. Disengage the choke (par. 5.2, type "I").

NOTE *Using the choke when the engine is already warm can foul the spark plugs and cause the engine to run erratically.*

11. When the engine has started, shift the throttle control to the minimum «tortoise» speed position.

NOTE *If there are engine starting problems, do not insist as you can risk running the battery flat and flooding the engine. Turn the key to the Off position, wait for a few seconds and then repeat the operation. If the malfunction persists, refer to the engine manual and chapter «14» in this manual.*

6.5 OPERATION

6.5.1 Forward gear and riding without mowing

When moving the machine:

- disengage the cutting means (par. 5.8);
- bring the cutting-means assembly to the highest position (position «7»);
- shift the throttle control to a point midway between the «tortoise» and «hare» speed positions.

For models with mechanical drive only:

1. Press the pedal all the way down (par. 5.4) and shift the gear lever to 1st gear (par. 5.5).
2. Hold the pedal down (fig. 10.1) then disengage the parking brake (par. 5.3).
3. Slowly release the pedal which will turn from «brake» to «clutch» mode, thus operating the rear wheels (par. 5.4).

⚠ The pedal has to be released gradually, as a sudden engagement may cause the vehicle to tip over and the driver to lose control.

4. Gradually reach the desired speed using the throttle and gear lever. To change gear, press the clutch halfway down (par. 5.4; par. 5.5).

For models with hydrostatic drive only:

1. Disengage the parking brake and release the brake pedal (par. 5.6).
2. Press the drive pedal (par. 5.7) in the "forward drive" direction and reach the required speed by gradually increasing pressure on the pedal and working the throttle.

⚠ Drive can only be engaged following the procedure illustrated (par. 5.7 to prevent sudden engagement which may cause the vehicle to tip over and the driver to lose control, especially on slopes.

6.5.2 Braking

First reduce the machine's speed by reducing the engine's r.p.m., and then press the brake pedal (par. 5.4; par. 5.6) to slow down the machine until it stops.

For models with hydrostatic drive only:

The machine already slows down considerably by just releasing the drive pedal (par. 5.7)

6.5.3 Reverse gear

IMPORTANT *Reverse must be engaged when the machine has stopped.*

For models with mechanical drive only:

1. Press the pedal (par. 5.4) until the machine comes to a stop;
2. Shift the gear lever to "R" reverse (par. 5.5).
3. Gradually release the pedal to engage the clutch and then begin moving in reverse.

For models with hydrostatic drive only:

1. Press the pedal (par. 5.6) until the machine comes to a stop;
2. start reversing by pressing the drive pedal in the "R" direction (par. 5.7).

6.5.4 Grass cutting

To operate with the machine proceed as described below:

1. shift the throttle to the maximum speed position ("hare"); this position is always used when using the machine;
2. bring the cutting-means assembly to the highest position;
3. engage the cutting means (par. 5.8) only on grass lawns; avoid engaging them on stony ground or when the grass is very high;
4. regulate the forward speed and the cutting height (par. 5.10) considering the conditions of the lawn (the height, density and dampness of the grass).
5. start moving forwards on the grass very slowly and with utmost caution, as already described;

IMPORTANT *To proceed in reverse gear with the cutting means engaged, it is necessary to press and hold the consent button (par. 5.9) so as not to cause the engine to stop.*

Lower the speed whenever you note a drop in engine speed, since a forward speed that is too fast compared to the amount of grass being cut will never mow the grass well.

Disengage the cutting means and move the cutting-means assembly to the highest position:

- When moving between work areas
- When driving on grass free surfaces
- Every time it is necessary to overcome an obstacle.

6.5.5 Suggestions for maintaining a nice lawn

1. To keep a lawn green and soft with a good appearance, it should be cut regularly. A lawn can be composed of different types of grass. If the lawn is cut frequently, grass and roots grow more vigorously, forming

a solid grassy bed. If the lawn is cut less frequently, higher grass and weeds start growing (clover and daisies, etc.).

2. It is always better to cut the grass when dry.
3. The cutting means must be in good condition and well sharpened so that the grass is cut straight without a ragged edge that leads to yellowing at the ends.
4. The engine must run at full speed, both to ensure a sharp cut of the grass and to get the necessary thrust to push the cuttings through the collector channel.
5. The frequency of mowing should be in relation to the rate of growth of the grass, which should not be left to grow too much between one cut and the next.
6. During hot and dry periods, the grass should be cut a little higher to prevent the ground from drying out.
7. The best height of the grass on a well-kept lawn is approx. 4-5 cm. and with one mowing, you do not need to remove more than a third of the total height. If the grass is very tall, it should be cut twice in a twenty-four hour period. The first time with the cutting means at maximum cutting height, possibly reducing the cutting width and the second cut at the height desired (fig. 20).
8. The appearance of the lawn will improve if you alternate the cutting in both directions (fig. 21).
9. If the discharge chute tends to get blocked with grass, you should reduce the forward speed as it may be too high for the condition of the grass. If the problem persists, the probable causes are either badly sharpened cutting means or deformed fins.
10. Be very careful when mowing near bushes or kerbs as these could distort the horizontal position of the cutting-means assembly and damage its edge as well as the cutting means.

6.5.6 Emptying the grass catcher (for rear collection models only)

NOTE *The emptying of the grass catcher can only be done with the cutting means disengaged, otherwise the engine stops.*

- Do not let the grass catcher become too full as this may block the collection channel.
- When the grass catcher is full you will hear a warning sound:
 1. disengage the cutting means (par. 5.8) and the audible signal will stop;
 2. shift the throttle control to minimum "tortoise" speed position (par. 5.7);
 3. stop moving forward and switch to neutral (par. 5.5; par. 5.7);

4. engage the parking brake;
5. stop the engine;
6. pull out the lever (fig. 22.A - if fitted) or grasp the rear handle (fig. 22.A1) and tip up the grass catcher to empty it;
7. close up the grass catcher so that it hooks onto the pawl (fig. 22.B).

6.5.7 Cleaning the discharge chute (for rear collection models only)

- Cutting very tall or wet grass, particularly at excessively high speed, can clog up the discharge chute. If it clogs, follow the instructions provided in chap. 7.4.2.

6.5.8 Mowing completed

When mowing has been completed:

1. disengage the cutting means;
2. decrease the engine's r.p.m.
3. drive back with the cutting-means assembly in its highest position:

6.6 STOP

To stop the machine:

1. shift the throttle lever to minimum "tortoise" speed position

⚠ To avoid backfire, leave the throttle in the minimum "tortoise" speed position for 20 seconds before switching off the engine.

2. switch off the engine by turning the ignition key to Off;
3. with the engine turned off, close the fuel tap (fig. 23.A) (if provided).
4. remove the key from the ignition

IMPORTANT *To keep the battery charged, do not leave the ignition key in the «on» or «headlights on» position when the engine is not running.*

⚠ The engine may be very warm immediately after it is shut off. Do not touch the exhaust or adjacent parts. This can cause burn injuries.

6.7 AFTER OPERATION

1. Allow the engine to cool before storing in an enclosed space.
2. Clean (par. 7.4).
3. Lower the cutting-means assembly, shift to neutral, engage the parking brake, turn off the engine and remove the

ignition key (checking that all moving parts are completely stationary):

- whenever the machine is left unattended, the operator dismounts from the driving seat, or parks the machine;

7. ROUTINE MAINTENANCE

7.1 GENERAL INFORMATION

⚠ *The safety regulations to follow are described in chap. 2. Strictly comply with these instructions to avoid serious risks or hazards.*

⚠ *Before conducting any inspections, cleaning or maintenance/adjustment interventions on the machine:*

- *disengage the cutting means;*
 - *shift into neutral;*
 - *engage the parking brake;*
 - *stop the engine;*
 - *remove the key, (never leave the keys in the ignition or within reach of children or unauthorised persons);*
 - *make sure that all moving parts have come to a complete stop;*
 - *read the relevant instructions;*
 - *Use suitable clothing, protective gloves and goggles*
- The frequency and types of maintenance are summarised in the "Maintenance Table". The table will help you maintain your machine's safety and performance. It lists the main maintenance tasks and how often they need to be performed. Carry out the relevant task as soon as it is scheduled to be performed.
- The use of non-genuine and/or incorrectly assembled spare parts and attachments could adversely affect machine operation and safety. The manufacturer shall decline all liability in the event of injuries or damages caused by such parts.
- Genuine spare parts are supplied by authorized assistance workshops and dealers.

7.2 REFUELLING / EMPTYING THE FUEL TANK

NOTE *The type of fuel to use is given in the engine manual.*

IMPORTANT *The machine is delivered to the client without fuel. Follow all the instructions in the engine manual.*

7.2.1 Refuelling

To refuel:

1. Unscrew the tank closure cap and remove it (fig. 24).
2. Insert the funnel (fig. 24).
3. Refuel being careful not to completely fill the tank.
4. Remove the funnel.
5. Close the fuel cap securely after refuelling and clean away any spills.

IMPORTANT *Do not drip petrol onto the plastic parts to avoid ruining them. In the event of accidental leaks, rinse immediately with water. The warranty does not cover for damage to plastic parts of the bodywork or the engine caused by petrol.*

7.2.2 Emptying the fuel tank

NOTE *Fuel is perishable and should not remain in the tank for more than 30 days. Empty the fuel tank before storing the machine for long periods of time (chap. 9).*

⚠ *Allow the engine to cool before emptying the fuel tank.*

1. Place the machine on a flat surface, in the open air.
2. Place a suitable container under the drain tube (fig. 26.A).
3. Disconnect the tube (fig. 26.A) installed on the fuel filter inlet (fig. 26.B).
4. Open the fuel tap (if provided)
5. Collect the fuel in a suitable container.
6. Reconnect the tube (fig. 26.A) making sure you position the clamp properly (fig. 26.C).
7. Close the fuel tap (if provided).

⚠ *The next time the machine is used, check that there are no fuel leaks from the tubes, fuel stopcock or carburettor.*

7.3 CHECK, TOP UP, DRAINING OF ENGINE OIL

NOTE *The type of oil to use is given in the engine manual.*

IMPORTANT *The machine is delivered to the client without engine oil.*

IMPORTANT *Follow all the instructions in the engine manual.*

7.3.1 Check/top-up

 **Always check the oil level before use.**

- Check the oil level: according to the instructions in the engine manual, this must be between the MIN and MAX marks on the dipstick (fig. 25).

 **Do not overfill as this could cause the engine to overheat. If the oil level exceeds the "MAX" mark, drain until the correct level is achieved.**

7.3.2 Draining

 **The oil may be very hot if removed just after the engine has been switched off. Consequently allow the engine to cool down for a few minutes before proceeding to drain off the oil.**

Replace the engine oil according to the frequency indicated in the engine instruction manual.

Proceed as follows:

• **Type "I":**

1. Place the machine on a flat surface.
2. Place a suitable container under the extension tube (fig. 27.A).
3. Hold the extension tube (fig. 27.A) firmly in place and unscrew the drain plug (fig. 27.B).
4. Collect the oil in a suitable vessel.
5. Replace the drain plug (fig. 27.B) making sure that the gasket is in the right position (fig. 27.C).
6. Fully tighten holding the extension tube firmly in place (fig. 27.A).
7. Clean up any spills.

• **Type "II":**

1. Unscrew the topping up cap (fig. 27.A).
2. Fit the tube (fig. 27.B) onto the syringe (fig. 27.C) and insert it as far as possible into the hole.
3. Using the syringe (fig. 27.C), suck up all the engine oil, bearing in mind that you need to repeat this operation a few times before all the oil is removed.

IMPORTANT *Hand the spent oil over to a disposal facility in accordance with local provisions.*

7.4 ANTI-CHIPPING WHEELS

The different heights of the wheels allow you to maintain a safe distance "H"

between the cutting-means assembly and the ground (fig. 16.A, fig. 17.A). Adjust the position of the anti-chipping wheels according to how irregular the ground is.

 This should always be performed on both wheels, positioning them at the same height **WITH THE ENGINE OFF AND CUTTING MEANS DISENGAGED.**

a. for models with side discharge only

To change the position:

1. unscrew and remove the screw (fig. 16.B)
2. reposition the wheel (fig. 16.A) with the spacer (fig. 16.C) inside the hole at the desired distance
3. fully tighten the screw (fig.16.B) onto the nut (fig. 16.D).

b. for models with rear collection only

To change the position:

1. unscrew the nut (fig. 17.B) and extract the pin (fig.17.C).
2. reposition the wheel (fig. 17.A) in the desired position
3. reassemble the pin (fig. 17.C), making sure the pin (fig. 17.C) head is facing toward the inside of the machine
4. then tighten the nut completely (fig. 17.B).

7.5 CLEANING

Clean thoroughly following the instructions below every time it is used.

7.5.1 Cleaning the machine

- Clean the outside of the machine washing the plastic parts of the bodywork with a damp sponge using water and detergent, taking care not to wet the engine, the electrical parts or the electronic circuit board located under the dashboard.
- To reduce fire hazards, keep the engine, silencer, battery compartment and petrol storage area free of grass, leaves, or excessive grease.

IMPORTANT *Never use hose-nozzles or harsh detergents for cleaning the body and engine!*

7.5.2 Cleaning the discharge chute (for rear collection models only)

If the discharge chute is clogged:

1. remove the grass catcher or the rear discharge guard;
2. remove the grass cuttings; you can reach them from the channel discharge opening.

7.5.3 Cleaning the grass catcher (for rear collection models only)

1. Empty the grass catcher
2. Shake it to remove grass cuttings and soil residue
3. Replace the grass catcher and clean the interior of the cutting-means assembly (par. 7.4.4-a), now remove the grass catcher, empty and rinse it, then place it where it can dry quickly.

7.5.4 Cleaning the cutting-means assembly

Clean the cutting-means assembly thoroughly to remove any grass remains or debris.

 **Keep people or animals away from the surrounding area when cleaning the cutting-means assembly.**

a. Cleaning the interiors

When washing the inside of the cutting-means assembly and the discharge chute, the machine must be on firm ground with:

- the grass catcher or the rear discharge guard mounted in place (for rear collection models only)
 - the side discharge chute mounted (for models with side discharge only);
 - the operator seated;
 - the cutting-means assembly in position «1»;
 - the engine running
 - the transmission in neutral
 - the cutting means engaged
- Connect a water hose to each of the pipe fittings (fig. 28.A; fig. 29.A) one at a time and run water through each one for a few minutes, with the cutting means moving.

IMPORTANT *In order not to compromise the efficiency of the electromagnetic clutch:*

- do not let the clutch come into contact with oil;
- do not spray pressurised water directly on the clutch unit;
- do not clean the clutch with petrol.

b. Cleaning the exterior

 **Do not let debris and dried grass accumulate in the upper part of the cutting-means assembly in order to maintain maximum machine efficiency and safety levels.**

To clean the upper part of the cutting-means assembly:

- lower the cutting-means assembly completely (position «1»);
- blow a jet of compressed air through the right and left guard openings (fig. 28; fig. 29).

7.6 BATTERY

To ensure long life to the battery it is essential to keep it carefully maintained.

The machine battery must always be charged:

- before using the machine for the first time after purchase;
- before leaving the machine disused for a long period (over 30 days) (par. 9);
- before starting up the machine after a prolonged period of inactivity.

Carefully read and observe the battery recharging instructions in the booklet provided with the battery. Failure in following the procedure or in charging the battery could permanently damage the battery elements. A flat battery **must** be recharged as soon as possible.

IMPORTANT *Recharging must be done using a battery charger at constant voltage. Other recharging systems can irreversibly damage the battery.*

- The machine comes with a connector (fig. 30.A) for recharging; this is connected to the corresponding connector for the special maintenance battery-charger supplied (if included) or available on request (par. 15.2).

IMPORTANT *This connector must only be used for connection to the maintenance battery-charger indicated by the Manufacturer. For its use:*

- follow the instructions given in the relative instructions manual;
- follow the instructions in the battery manual;

7.7 NUTS AND BOLTS

- Keep all nuts, bolts and screws tight to be sure the equipment is in safe working condition.

8. EXTRAORDINARY MAINTENANCE

8.1 SAFETY RECOMMENDATIONS

 **You must go to a specialized Service Centre or contact your Dealer if the following are malfunctioning:**

- the brake

- **the cutting means engage and disengage functions**
- **switching the drive to forward or reverse gears.**

8.2 CUTTING-MEANS ASSEMBLY / CUTTING MEANS

8.2.1 Aligning the cutting-means assembly

The cutting-means assembly should be properly adjusted to obtain an evenly mown lawn (fig. 31). If mowing is uneven, check the tyre pressure (par. 6.1.3). If this is not sufficient to achieve an even cut, please contact your Dealer to adjust the alignment of the cutting-means assembly.

8.2.2 Cutting means

A badly sharpened cutting means pulls at the grass and causes the lawn to turn yellow.

⚠ All work on the cutting means (disassembly, sharpening, balancing, repairing, reassembly and/or replacing) are demanding jobs that require special skills as well as special tools. For safety reasons, these jobs are best carried out at a Specialised Centre.

⚠ Make sure damaged, misshapen or worn cutting means are replaced as a whole unit, together with its own screws in place to preserve balance.

IMPORTANT *Cutting means should be replaced in pairs, especially when there are marked differences in wear.*

IMPORTANT *Always use original cutting means bearing the code indicated in the "Technical Data".*

Given product evolution, the cutting means listed in the "Technical Data" table may be replaced in time with others having similar interchangeable and operating safety features.

8.3 REPLACING OF FRONT / REAR WHEELS

8.3.1 Preparation

IMPORTANT *Use a suitable lifting device, for example a scissor jack.*

Before changing the wheels it is necessary to complete some preliminary operations:

- Remove all attachments.
- Position the machine on a solid and even surface that guarantees stability of the machine.
- Engage the parking brake;
- Stop the engine;
- Remove the key from the ignition;
- Position the jack in the lifting position near the wheel to be changed (par. 8.3.2; par. 8.3.3).
- Check that the jack is perfectly perpendicular to the ground.

8.3.2 Choice and positioning of the jack on the rear wheels

Position some wooden wedges (fig. 31.A) to the wheel base (fig. 31.B) to the side of the wheel to be changed (fig. 31.C).

For models with rear collection:

- The maximum possible jack height when closed is 110 mm. (fig. 32).
- Position the jack under the rear plate (fig. 33.A) at 180 mm from the side edge.

For side discharge models:

- The maximum possible jack height when closed is 110 mm. (fig. 34).
- Position the jack under the rear axle, in the point indicated in the diagram (fig. 35.A).

NOTE *In this position the jack allows you to only raise the wheel to be changed.*

8.3.3 Choice and positioning of the jack on the front wheels

1. Position some wooden wedges (fig. 36.A) to the wheel base (fig. 36.B) behind the wheel to be changed (fig. 36.C).
2. The maximum possible jack height when closed is 110 mm.
3. Position a square 10 x 10 cm wooden wedge (fig. 37.B) on the jack (fig. 37.A).

NOTE *The wooden wedge prevents damage to the front axle.*

4. Raise the jack so that the wedge rests against the chassis and structural parts (fig. 37.C).

NOTE *During this phase use your hand to keep the wedge balanced correctly on the jack.*

NOTE *In this position the jack allows you to raise the entire front axle.*

8.3.4 Changing the wheel

IMPORTANT *Make certain the machine remains still and stable during the lifting process. If you notice anything out of the ordinary, lower the jack immediately, check and resolve any problems and lift the machine again.*

1. Remove the cover (fig. 38.A).
2. Raise it enough to extract the wheel easily.
3. Using a screwdriver, remove the snap ring (fig. 38.B) and the shoulder washer (fig. 38.C).
4. Remove the wheel to be changed.
5. Coat the axle (fig. 38.D) with grease.
6. Mount the spare wheel.
7. Carefully replace the shoulder washer and snap ring.

IMPORTANT *Check that the two rear wheels are the same height (fig. 39.A) and that the difference between the external diameters of the two wheels (fig. 39.B) is no greater than 8-10 mm. On the contrary, to avoid uneven mowing, the cutting-means assembly must be aligned by an authorised service centre.*

8.3.5 Repairing or changing tyres

The tyres are “Tubeless” and so all punctures must be repaired by a tyre repairer following the procedures required for this kind of tyre.

8.4 ELECTRONIC CIRCUIT BOARD

The electronic circuit board is a component fitted below the dashboard which manages all machine safety devices.

8.4.1 Electronic circuit board protection device (for rear collection models only)

- The electronic circuit board is located below the dashboard and fitted with a self-setting protection which breaks the circuit if there is a fault or short circuit on the electrical system (chap. 14).

8.4.2 Electronic circuit board protection fuse (for side discharge models only)

- The electronic circuit board is located below the dashboard and fitted with a fuse which breaks the circuit if there is a fault or short circuit on the electrical system (chap. 14).

8.5 REPLACING A FUSE

The machine is fitted with fuses (fig. 40.A) with different capacities and functions. Specifically:

- 10 A fuse = protects the main and power circuits of the electronic circuit board. When it blows, the machine stops and the dashboard light switches off (**for rear discharge models only** (par. 5.11))
- 25 A fuse = protects the battery recharge circuit. When it blows, the battery gradually runs down and the machine will have problems starting.

The fuse capacity is indicated on the fuse.

IMPORTANT *A blown fuse must always be replaced by one of the same type and ampere rating, and never with one of another rating.*

If you are unable to understand why it has blown, contact Your Dealer.

8.6 REPLACING BULBS

8.6.1 Type "I" - Incandescent light bulbs

- The bulbs (18W) have a bayonet fitting and are installed in the bulb holder which can be taken out by turning it anti-clockwise with pliers (fig. 41).

8.6.2 Type "II" - LED light bulbs

- Loosen the lock nut (fig. 41.A) and remove the connector (fig. 41.B). Remove the LED illuminator (fig. 41.C), secured by screws (fig. 41.D).

8.7 REAR AXLE

- This is a sealed single unit that does not require maintenance. It is permanently lubricated and its lubricant does not need changing or topping up.

9. STORING THE MACHINE

When you intend to put your machine away for more than 30 days:

1. Wait for the engine to cool
2. Disconnect the battery cables and store it in a cool and dry place.
3. Empty the fuel tank (par. 7.2.2) and follow all the instructions in the engine manual.
4. Clean the machine thoroughly.

5. Check the machine for any damage. If necessary, contact the authorised assistance centre.
6. Store the machine:
 - with the cutting-means assembly lowered
 - in a dry place
 - protected from inclement weather
 - and covered with a sheet where possible (par. 15.4)
 - in a place where children cannot get to it
 - making sure that keys or tools used for maintenance are removed.

Before starting to use the machine again:

- check that there are no fuel leaks from the tubes, fuel stopcock or carburettor.
- prepare the machine as described in chapter "6. Using the machine" .

10. HANDLING AND TRANSPORTATION

- When handling the machine, always:
 - disengage the cutting means;
 - bring the cutting-means assembly to the highest position;
 - stop the engine;
- When transporting the machine on a vehicle or trailer, always:
 - use an access ramp of suitable strength, width and length;
 - load the machine with the engine switched off, with the key removed from the ignition, without a driver and pushed by an adequate number of people;
 - close the fuel tap (if provided);
 - lower the cutting-means assembly;
 - engage the parking brake;
 - position it so that it can not cause a hazard for anybody;
 - fasten firmly to the means of transport using ropes or chains to prevent it from tipping over causing damage and fuel leaks.

11. ASSISTANCE AND REPAIRS

This manual provides all the necessary information to run the machine and for correct basic maintenance operations which can be performed by the user. Any regulations and maintenance operations not described herein must be carried out by your Dealer

or Authorized Service Centre, which have the necessary knowledge and equipment to ensure that the work is carried out correctly, maintaining the correct degree of safety and the original operating conditions of the machine. Any operations performed in unauthorized centres or by unqualified persons will totally invalidate the Warranty and all obligations and responsibilities of the Manufacturer.

- Only authorized service workshops can carry out guaranteed repairs and maintenance.
- The authorized service workshops only use genuine spare parts. Genuine spare parts and attachments have been designed specifically for machines.
- Non-original parts and attachments are not approved; use of non-original spare parts and attachments will jeopardize the safety of the machine and relieve the Manufacturer from all obligations or liabilities.
- It is advisable to send your machine once a year to an authorized service workshop for servicing, assistance and safety device inspection.

12. WARRANTY COVERAGE

The warranty covers all material and manufacturing defects. The user must follow all the instructions provided in the accompanying documentation.

The warranty does not cover damages caused by:

- Failure to become familiar with the documentation accompanying the machine.
- Carelessness.
- Incorrect or prohibited use or assembly.
- Use of non-genuine spare parts.
- Use of attachments not supplied or approved by the manufacturer.

The warranty does not cover:

- Normal wear and tear of consumables, such as drive belts, headlights, wheels, blades, safety bolts and wires.
- Normal wear and tear.
- Engines. Engines are covered by the warranty provided by the relative manufacturer in compliance with the specified terms and conditions.

The purchaser is protected by his own national legislation. The purchaser's rights envisaged by the national laws in his own country are not in any way restricted by this warranty.

13. MAINTENANCE TABLE

The boxes at the side are for you to mark the date or number of working hours at which the intervention was made.

Operation	Frequency (hours)	Completed (Date or Hours)					Notes
MACHINE							
Safety checks/check controls	Before each use						par. 6.2
Tyre pressure check	Before each use						par. 6.1.3
Assembly/Checking of outlet guards	Before each use						par. 6.1.4
General cleaning and inspection	After each use						par. 7.4
Checking for any damage to the machine. If necessary, contact the authorised assistance centre.	After each use						-
Battery power reserve	Before storage						par. 7.5
Complete bolt and screw check	25						
Cutting means positioning and sharpening check	25						***
Transmission belt check	25						***
Cutting means control belt check	25						***
Brake regulation and check	25						***
Drive regulation and check	25						***
Cutting means gear and brake check	25						***
General lubrication	25						****
Replacing cutting means	100						***
Replacing the transmission belt	-						** / ***
Replacing the cutting means control belt	-						** / ***
ENGINE							
Checking/topping up fuel level	Before each use						par 7.2
Check/top-up engine oil	Before each use						par 7.3
Replacement of the engine oil	...						*
Air filter cleaning and check	...						*
Air filter replacement	...						*
Fuel filter check	...						*
Fuel filter replacement	...						*
Spark plug points cleaning and check	...						*
Replace the spark plug	...						*

* See the engine manual for the full list and frequency

** At the first signs of any malfunction, contact your Dealer immediately

*** The operation must be carried out by your Dealer or a specialized Service Centre

**** General lubrication of all joints should also be carried out whenever the machine is to be left unused for a long period.

14. PROBLEM IDENTIFICATION

PROBLEM	PROBABLE CAUSE	REMEDY
1. With the key turned to «ON», the light stays off (<i>for rear collection models only</i>)	The safety device of the electronic circuit board has cut in due to:	Turn the ignition key to «STOP» position and look for the cause of the problem:
	badly connected battery	check the connections (par. 4.4)
	battery terminals crossed	check the connections (par. 4.4).
	flat battery	recharge the battery (par. 7.5)
	fuse blown	replace fuse (10 A) (par. 8.5).
	wet circuit board	dry using luke warm air
2. With the key turned to «START» the light flashes and the starter motor does not run (<i>for rear collection models only</i>)	starting conditions have not been met	check that all starting conditions are met (par. 6.2.2)
3. With the key turned to «START» the light is on but the starter motor does not run (<i>for rear collection models only</i>)	insufficiently charged battery	recharge the battery (par. 7.5)
	malfunction on the starter relay	contact your Dealer

If problems persist after having performed the above operations, contact your dealer.

PROBLEM	PROBABLE CAUSE	REMEDY
4. With the key turned to «START» the starter motor does not run (for side discharge models only)		Turn the ignition key to «STOP» position and look for the cause of the problem:
	starting conditions have not been met	check that all starting conditions are met (par. 6.2.2)
	badly connected battery	check the connections (par. 4.4)
	battery terminals crossed	check the connections (par. 4.4)
	flat battery	recharge the battery (par. 7.5)
	fuse blown	replace fuse (10 A) (par. 8.5).
	wet circuit board	dry using luke warm air
5. With the key on «START» the starter motor runs but the engine does not start	insufficiently charged battery	recharge the battery (par. 7.5)
	faulty fuel supply	check the level in the tank (par. 7.2.1)
		open the fuel stopcock (if foreseen) (par. 6.4)
		check the fuel filter
	faulty ignition	check that spark plug cap is securely fitted
check that the electrodes are clean and have the correct gap		
6. Starting is difficult or the engine runs erratically	carburation problems	clean or replace the air filter
		empty the fuel tank and refill with fresh fuel
		check and replace the fuel filter if necessary
7. Weak engine performance during cutting	forward speed too high in relation to cutting height	reduce the forward speed and/or raise the cutting height (par. 6.5.4)
8. The engine shuts down whilst working	the safety devices have cut in	check that all starting conditions are met (par. 6.2.2)
	blown fuse due to a short circuit or electrical system faults (for side discharge models only)	The cause of the fault should be ascertained and dealt with to avoid reactivating the protection device Replace the fuse (10 A) (par. 8.5). Contact your Dealer if such interruptions continue
9. The engine stops whilst operating and the indicator light switches off (for rear collection models only)	The safety device of the electronic circuit board has cut in due to:	Turn the ignition key to «STOP», wait for a couple of seconds to allow the circuit to reset automatically and:
	battery terminals crossed	check the connections (par. 4.4)
	faults in the battery charging regulator	check the battery connections (par. 4.4)
		check the battery is fitted
short circuit	contact your Dealer	
10. The cutting means do not engage or do not stop promptly when they are disengaged	problems with engagement mechanism	contact your Dealer

If problems persist after having performed the above operations, contact your dealer.

PROBLEM	PROBABLE CAUSE	REMEDY
11. Uneven mowing and insufficient collection <i>(for rear collection models only)</i>	cutting-means assembly is not parallel to the ground	check the tyre pressure (par. 6.1.3)
		reinstate the alignment of the cutting-means assembly in relation to the ground (par. 8.2.1)
	inefficient cutting means	contact your Dealer
	forward speed too high compared to height of grass	reduce the forward speed and/or raise the cutting-means assembly (par. 6.5.4)
		wait for the grass to dry
collector channel is blocked	remove the grass catcher and empty the discharge chute (par. 7.4.2)	
12. Uneven mowing <i>for side (discharge models only)</i>	cutting-means assembly is not parallel to the ground	check the tyre pressure (par. 6.1.3)
		reinstate the alignment of the cutting-means assembly in relation to the ground (par. 8.2.1)
	inefficient cutting means	contact your Dealer
13. Unusual vibrations while working	cutting-means assembly is full of grass	clean the cutting-means assembly (par. 7.4.4)
	the cutting means are unbalanced or loose	contact your Dealer
	loose bolts and screws	check and tighten all the engine and frame bolts
14. Uncertain or ineffective braking	the brake is not adjusted correctly	contact your Dealer
15. Erratic forward movement, poor drive when going uphill or if the machine has a tendency to rear up	problems with the belt or the engagement device	contact your Dealer
16. With the engine running, the machine does not move when the drive pedal is pressed (hydrostatic transmission models)	release lever in the gear disengagement position	return it to the gear engaged position (par. 5.13)
17. The machine starts to vibrate abnormally and/or has hit an object	damaged or loose parts	stop the machine and remove the ignition key
		inspect for damage
		check for and tighten any loose parts
		have all checks, repair work and replacements carried out by a specialized Centre only.

If problems persist after having performed the above operations, contact your dealer.

15. ATTACHMENTS

15.1 "MULCHING" KIT

It finely chops the grass cuttings and leaves them on the lawn (fig. 42.A1; fig 42.A2).

15.2 MAINTENANCE BATTERY CHARGER

This keeps the battery in good working order when the machine is in storage, guaranteeing an optimum level of charge and longer battery life (fig. 42.B).

15.3 TOWING KIT

To tow a small trailer (fig. 42.C).

15.4 CANVAS COVER

Protects the machine from dust when not in use (fig. 42.D)

15.5 REAR DISCHARGE GUARD KIT

Used instead of the grass catcher when the cuttings are not collected (fig.42.E).
(For rear discharge models only).

15.6 18" SNOW CHAINS

These improve front wheel adherence on snow-covered sections of road and allow the snow shovel equipment to be used (fig. 42.F).

15.7 18" MUD / SNOW WHEELS

These improve drive performance on snow and mud.

15.8 TRAILER

For transporting tools and other objects within the allowed load limits (fig. 42.H).

15.9 SPRINKLER

To sprinkle salt or fertilisers (fig. 42.I).

15.10 GRASS ROLLER

To make the soil compact after seeding or to flatten the grass (fig. 42.J).

15.11 SNOW BLADE

Shovels and accumulates removed snow to the side (fig. 42.K).

15.12 LEAF AND GRASS COLLECTOR

For the collection of leaves and grass on lawn surfaces (fig. 42.L).

DICHIARAZIONE CE DI CONFORMITÀ (Istruzioni Originali)

(Direttiva Macchine 2006/42/CE, Allegato II, parte A)

1. **La Società:** STIGA S.p.A. – Via del Lavoro, 6 – 31033 Castelfranco Veneto (TV) – Italy
2. Dichiaro sotto la propria responsabilità, che la macchina: Tosaerba con conducente a bordo seduto / taglio erba

- a) Tipo / Modello Base
b) Mese/Anno di costruzione
c) Matricola

MP 84

d) Motore a scoppio

3. È conforme alle specifiche delle direttive:

- MD: 2006/42/EC
- e) Ente Certificatore: /
- f) Esame CE del tipo: /
- OND: 2000/14/EC, ANNEX VI - 2005/88/EC
D. Lgs. 262/2002, ANNEX VI, proc. 1 (Italy)
- e) Ente Certificatore:
- EMCD: 2014/30/EU

N°0197-TÜV Rheinland LGA Products GmbH
Tillystrasse 2, 90431 Nürnberg – Germany

4. Riferimento alle Norme armonizzate:

EN ISO 5395-1:2013+A1:2018 EN 55012:2007/A1:2009
EN ISO 5395-3:2013+A1:2017+A2:2018 EN ISO 14982:2009

g) Livello di potenza sonora misurato 100 dB(A)
h) Livello di potenza sonora garantito 100 dB(A)
i) Ampiezza di taglio 83 cm

- n) Persona autorizzata a costituire il Fascicolo Tecnico:

STIGA S.p.A.
Via del Lavoro, 6
31033 Castelfranco Veneto (TV) - Italia

- o) Castelfranco V.to, 01.06.2018

Senior VP R&D & Engineering
Maurizio Tursini



DICHIARAZIONE CE DI CONFORMITÀ (Istruzioni Originali)

(Direttiva Macchine 2006/42/CE, Allegato II, parte A)

1. **La Società:** STIGA S.p.A. – Via del Lavoro, 6 – 31033 Castelfranco Veneto (TV) – Italy
2. Dichiaro sotto la propria responsabilità, che la macchina: Tosaerba con conducente a bordo seduto / taglio erba

a) Tipo / Modello Base

MP 98

b) Mese/Anno di costruzione

c) Matricola

d) Motore

a scoppio

3. È conforme alle specifiche delle direttive:

- MD: 2006/42/EC
- e) Ente Certificatore: /
- f) Esame CE del tipo: /
- OND: 2000/14/EC, ANNEX VI - 2005/88/EC
D. Lgs. 262/2002, ANNEX VI, proc. 1 (Italy)
- e) Ente Certificatore:

N°0197-TÜV Rheinland LGA Products GmbH
Tillystrasse 2, 90431 Nürnberg – Germany

- EMCD: 2014/30/EU

4. Riferimento alle Norme armonizzate:

EN ISO 5395-1:2013+A1:2018

EN 55012:2007/A1:2009

EN ISO 5395-3:2013+A1:2017+A2:2018

EN ISO 14982:2009

g) Livello di potenza sonora misurato

100 dB(A)

h) Livello di potenza sonora garantito

100 dB(A)

i) Ampiezza di taglio

97 cm

n) Persona autorizzata a costituire il Fascicolo Tecnico:

STIGA S.p.A.
Via del Lavoro, 6
31033 Castelfranco Veneto (TV) - Italia

o) Castelfranco V.to, 01.06.2018

Senior VP R&D & Engineering
Maurizio Tursini



DICHIARAZIONE CE DI CONFORMITÀ (Istruzioni Originali)

(Direttiva Macchine 2006/42/CE, Allegato II, parte A)

1. **La Società:** STIGA S.p.A. – Via del Lavoro, 6 – 31033 Castelfranco Veneto (TV) – Italy
2. Dichiaro sotto la propria responsabilità, che la macchina: Tosaerba con conducente a bordo seduto / taglio erba

a) Tipo / Modello Base

SD 98

b) Mese/Anno di costruzione

c) Matricola

d) Motore

a scoppio

3. È conforme alle specifiche delle direttive:

- MD: 2006/42/EC
- e) Ente Certificatore: /
- f) Esame CE del tipo: /
- OND: 2000/14/EC, ANNEX VI - 2005/88/EC
D. Lgs. 262/2002, ANNEX VI, proc. 1 (Italy)
- e) Ente Certificatore:

N°0197-TÜV Rheinland LGA Products GmbH
Tillystrasse 2, 90431 Nürnberg – Germany

- EMCD: 2014/30/EU

4. Riferimento alle Norme armonizzate:

EN ISO 5395-1:2013+A1:2018

EN 55012:2007/A1:2009

EN ISO 5395-3:2013+A1:2017+A2:2018

EN ISO 14982:2009

g) Livello di potenza sonora misurato

99 dB(A)

h) Livello di potenza sonora garantito

100 dB(A)

i) Ampiezza di taglio

98 cm

n) Persona autorizzata a costituire il Fascicolo Tecnico:

STIGA S.p.A.
Via del Lavoro, 6
31033 Castelfranco Veneto (TV) - Italia

o) Castelfranco V.to, 05.06.2018

Senior VP R&D & Engineering
Maurizio Tursini



DICHIARAZIONE CE DI CONFORMITÀ (Istruzioni Originali)

(Direttiva Macchine 2006/42/CE, Allegato II, parte A)

1. **La Società:** STIGA S.p.A. – Via del Lavoro, 6 – 31033 Castelfranco Veneto (TV) – Italy
2. Dichiaro sotto la propria responsabilità, che la macchina: Tosaerba con conducente a bordo seduto / taglio erba

a) Tipo / Modello Base

SD 108

b) Mese/Anno di costruzione

c) Matricola

d) Motore

a scoppio

3. È conforme alle specifiche delle direttive:

- MD: 2006/42/EC
- e) Ente Certificatore: /
- f) Esame CE del tipo: /
- OND: 2000/14/EC, ANNEX VI - 2005/88/EC
D. Lgs. 262/2002, ANNEX VI, proc. 1 (Italy)
- e) Ente Certificatore:

N°0197-TÜV Rheinland LGA Products GmbH
Tillystrasse 2, 90431 Nürnberg – Germany

- EMCD: 2014/30/EU

4. Riferimento alle Norme armonizzate:

EN ISO 5395-1:2013+A1:2018

EN 55012:2007/A1:2009

EN ISO 5395-3:2013+A1:2017+A2:2018

EN ISO 14982:2009

g) Livello di potenza sonora misurato

99 dB(A)

h) Livello di potenza sonora garantito

100 dB(A)

i) Ampiezza di taglio

107 cm

n) Persona autorizzata a costituire il Fascicolo Tecnico:

STIGA S.p.A.
Via del Lavoro, 6
31033 Castelfranco Veneto (TV) - Italia

o) Castelfranco V.to, 06.06.2018

Senior VP R&D & Engineering
Maurizio Tursini



FR (Traduction de la notice originale)	EN (Translation of the original instruction)	DE (Übersetzung der Originalhinweise/Anleitung)	NO (Oversettelse av original brukerveiledning)	BV (Oversättning av bruksanvisningen (original))	DA (Oversættelse af den originale brugsanvisning)
<p>Declaration CE de Conformité Directiva Machines 2006/42/CE, Annex II, parte A</p> <p>1. La Société 2. Declara sous sa propre responsabilité que la machine: Tendance à gagner ou conserver assés coupe de gazon a) Type/Modelo de Base b) Matière / Matière de construction c) Série d) Motor: motor essence 3. Est conforme aux prescriptions des directives suivantes: a) Directive de harmonisation b) Examen CE de Type c) Niveau de puissance mesuré d) Niveau de puissance sonore garanti e) Largeur de coupe f) Personne habilitée à établir le certificat Technique g) Liste de Date</p>	<p>EC Declaration of Conformity Directive Machines 2006/42/CE, Annex II, part A</p> <p>1. The Company 2. hereby declares under its own responsibility that the machine: ride on lawnmower with variable cutting / Grass cutting a) Type / Modelo de Base b) Matter / Matter of manufacture c) Serial number d) Motor: spark 3. Conforms to directive specifications: a) CE Certification b) EEC examination of Type c) Harmonized Standards d) Power level measured e) Guaranteed power level f) Range of cut g) Person authorized to create the Technical Folder h) Place and Date</p>	<p>CE-Konformitätserklärung Richtlinie Maschinen 2006/42/EG, Anhang II, Teil A</p> <p>1. Die Gesellschaft 2. erklärt auf eigene Verantwortung, dass die Maschine: Aufschiebermähdrescher / Rasenmäher a) Typ / Bauform b) Material / Bauelemente c) Seriennummer d) Motor: Verbrennungsmotor 3. Der Aufschiebermähdrescher ist folgenden Richtlinien entspricht: a) CE-Zertifizierung b) Zertifikatserklärung c) Harmonisierte Standards d) Besorgene auf die harmonisierten Normen e) Gemessene Schalldruckpegel f) Garantierte Schnittstufenbreite g) Schnittbreite h) Person, der die technischen Unterlagen erstellt hat i) Ort und Datum</p>	<p>EF - Samværetserklæring Maskinerivordning 2006/42/EF, Vedlegg II, del A</p> <p>1. Firmaet 2. Erklærer på eget ansvar at maskinen: Slagmaskine / grassklipper a) Type (Model) b) Materiel / Byggekl. c) Seriennummer d) Motor: forbrenningsmotor 3. Oppføreren erklærer i tillegg: a) CE-tilsvarende b) Oppførers erklæring c) Harmoniserte standarder d) Målt effekt e) Garantierte snittebredde f) Målt lydtrykknivå g) Garantierte skjæregrenser h) Person som har fulført til å utarbeide tekniske dokumenter i) Sted og dato</p>	<p>EG-forordningen om direktivföreläggelse (Maskinerivordning 2006/42/EG, bilaga II, del A)</p> <p>1. Företaget 2. Erklærer på eget ansvar att maskinen: Gräsklippare / gräsklippare a) Typ / Modell b) Material / Tillverkningsmaterial c) Seriennummer d) Motor: förbränningsmotor 3. Överensstämmer med direktiv A i EG-förordningen. Anmält organ f) Typgodkännande g) Harmoniserade standarder h) Mätt effekt i) Garantierad klippbredd j) Mått lydtryknivå k) Garantierad skärgräns l) Person som har utförat till utarbetat tekniska dokumenter m) Ställe och datum</p>	<p>EF-overensstemmelseserklæring Maskinerivordning 2006/42/EF, bilag II, del A)</p> <p>1. Firmaet 2. Erklærer på eget ansvar, at maskinen: Haverterklæpper / klipning af græsset a) Type / Model b) Materiel / Konstruktionsmateriel c) Seriennummer 3. Eftersvarende med specifikationer i tillæg A til EF-forskriften: a) CE-tilsvarende b) Udgørelsesattest c) Harmoniserede standarder d) Målt effekt e) Garantierte klippebredde f) Målt lydtrykkniveau g) Garantierte skæregrenser h) Personen, der har fremfyldt til at udarbejde tekniske dokumenter i) Sted og dato</p>
<p>EN: Verifying that the original notice is being translated</p> <p>ES: Verificar que el original de la instrucción está siendo traducido</p> <p>FR: Vérifier que la notice originale est traduite</p> <p>DE: Überprüfen, ob die Originalhinweise/Anleitung übersetzt werden</p> <p>NO: Sjekk at opprinnende brukerveiledning er oversatt</p> <p>BV: Kontrollera att den ursprungliga bruksanvisningen översätts</p> <p>DA: Tjekke om den originale brugsanvisning er oversat</p>	<p>Declaration de Conformité CE Directiva Machines 2006/42/CE, Annex II, parte A</p> <p>1. La Empresa 2. Declara bajo su propia responsabilidad que la máquina: cortacésped con altura de corte variable / cortacésped con altura de corte ajustable a) Tipo / Modelo Base b) Materia / Materia de fabricación c) Número de serie 3. Cumple con las especificaciones de las directivas: a) Examen CE de Tipo b) Referencia a las Normas armonizadas c) Nivel de potencia sonora medido d) Nivel de potencia sonora garantizado e) Amplitud de corte f) Persona autorizada a realizar el Manual Técnico g) Lugar y Fecha</p>	<p>Declaração de Conformidade CE Directiva de Máquinas 2006/42/CE, Anexo II, parte A</p> <p>1. A Empresa 2. Declara sob a própria responsabilidade que o equipamento: cortador de grama com altura de corte variável / cortador de grama com altura de corte ajustável a) Tipo / Modelo Base b) Material / Material de fabricação c) Número de série 3. E conforme às especificações das diretivas: a) Exame CE do Tipo b) Referência às Normas harmonizadas c) Nível medido de potência sonora d) Nível garantido de potência sonora e) Amplitude de corte f) Pessoa autorizada a elaborar o Caderno Técnico g) Local e Data</p>	<p>EF-VÅRSTÅTSEMMEKJÆNNING (Konformitetserklæring 2006/42/EF, bilag II, del A)</p> <p>1. Firmaet 2. Værdier om på eget ansvar, at maskinen: Græsbeskædning / roborstokk a) Type / Produkt b) Materiel / Byggekl. c) Seriennummer d) Motor: forbrændingsmotor 3. Overensstemmer med specifikationerne i tillæg A til EF-forskriften: a) CE-tilsvarende b) Udgørelsesattest c) Harmoniserede standarder d) Målt effekt e) Garantierte klippebredde f) Målt lydtrykkniveau g) Garantierte skæregrenser h) Personen, der har fulført til at udarbejde tekniske dokumenter i) Sted og dato</p>	<p>ES - Probación e ahoiti (Erklæring o tilsvarende tilsvarende 2006/42/EF, bilaga II, del A)</p> <p>1. Spoločnosť 2. Prohlasuje na vlastnú zodpovednosť, že stroj: Sekáčka so nastaviteľnou výškou na trávnu a) Typ / Model základného b) Materiál / Materiál výroby c) Sériové číslo d) Motor: spaľovací motor 3. Je v súlade s požiadavkami špecifikácie v prílohe A k smernici 2006/42/ES: a) Certifikácia typu b) Odkaz na harmonizované normy c) Měřená akustická výkonová moc d) Garantiovaná akustická výkonová moc e) Rozsah strihu f) Osoba autorizovaná na poskytnutie technického opisu g) Miesto a dátum</p>	<p>PL: Potwierdzenie niezgodności (originalna)</p> <p>ES - Declaración de conformidad (Directiva 2006/42/CE de los equipos, anexo II, parte A)</p> <p>1. La Empresa 2. Declara bajo su propia responsabilidad que el equipo: Cortacésped con altura de corte variable / cortacésped con altura de corte ajustable a) Tipo / Modelo Base b) Material / Material de fabricación c) Número de serie 3. Cumple con las especificaciones de las directivas: a) Examen CE de Tipo b) Referencia a las Normas armonizadas c) Nivel de potencia sonora medido d) Nivel de potencia sonora garantizado e) Amplitud de corte f) Persona autorizada a realizar el Manual Técnico g) Lugar y Fecha</p>
<p>EL: Μετάφραση της αρχικής οδηγίας χρήσης</p> <p>FR: Vérifier que la notice originale est traduite</p> <p>DE: Überprüfen, ob die Originalhinweise/Anleitung übersetzt werden</p> <p>NO: Sjekk at opprinnende brukerveiledning er oversatt</p> <p>BV: Kontrollera att den ursprungliga bruksanvisningen översätts</p> <p>DA: Tjekke om den originale brugsanvisning er oversat</p>	<p>AT: Überprüfung der Originalanweisung</p> <p>ES: Verificar que el original de la instrucción está siendo traducido</p> <p>FR: Vérifier que la notice originale est traduite</p> <p>DE: Überprüfen, ob die Originalhinweise/Anleitung übersetzt werden</p> <p>NO: Sjekk at opprinnende brukerveiledning er oversatt</p> <p>BV: Kontrollera att den ursprungliga bruksanvisningen översätts</p> <p>DA: Tjekke om den originale brugsanvisning er oversat</p>	<p>FR: Vérifier que la notice originale est traduite</p> <p>DE: Überprüfen, ob die Originalhinweise/Anleitung übersetzt werden</p> <p>NO: Sjekk at opprinnende brukerveiledning er oversatt</p> <p>BV: Kontrollera att den ursprungliga bruksanvisningen översätts</p> <p>DA: Tjekke om den originale brugsanvisning er oversat</p>	<p>NO: Sjekk at opprinnende brukerveiledning er oversatt</p> <p>BV: Kontrollera att den ursprungliga bruksanvisningen översätts</p> <p>DA: Tjekke om den originale brugsanvisning er oversat</p>	<p>ES - Probación e ahoiti (Erklæring o tilsvarende tilsvarende 2006/42/EF, bilaga II, del A)</p> <p>1. Spoločnosť 2. Prohlasuje na vlastnú zodpovednosť, že stroj: Sekáčka so nastaviteľnou výškou na trávnu a) Typ / Model základného b) Materiál / Materiál výroby c) Sériové číslo d) Motor: spaľovací motor 3. Je v súlade s požiadavkami špecifikácie v prílohe A k smernici 2006/42/ES: a) Certifikácia typu b) Odkaz na harmonizované normy c) Měřená akustická výkonová moc d) Garantiovaná akustická výkonová moc e) Rozsah strihu f) Osoba autorizovaná na poskytnutie technického opisu g) Miesto a dátum</p>	<p>PL: Potwierdzenie niezgodności (originalna)</p> <p>ES - Declaración de conformidad (Directiva 2006/42/CE de los equipos, anexo II, parte A)</p> <p>1. La Empresa 2. Declara bajo su propia responsabilidad que el equipo: Cortacésped con altura de corte variable / cortacésped con altura de corte ajustable a) Tipo / Modelo Base b) Material / Material de fabricación c) Número de serie 3. Cumple con las especificaciones de las directivas: a) Examen CE de Tipo b) Referencia a las Normas armonizadas c) Nivel de potencia sonora medido d) Nivel de potencia sonora garantizado e) Amplitud de corte f) Persona autorizada a realizar el Manual Técnico g) Lugar y Fecha</p>
<p>EL: Μετάφραση της αρχικής οδηγίας χρήσης</p> <p>FR: Vérifier que la notice originale est traduite</p> <p>DE: Überprüfen, ob die Originalhinweise/Anleitung übersetzt werden</p> <p>NO: Sjekk at opprinnende brukerveiledning er oversatt</p> <p>BV: Kontrollera att den ursprungliga bruksanvisningen översätts</p> <p>DA: Tjekke om den originale brugsanvisning er oversat</p>	<p>AT: Überprüfung der Originalanweisung</p> <p>ES: Verificar que el original de la instrucción está siendo traducido</p> <p>FR: Vérifier que la notice originale est traduite</p> <p>DE: Überprüfen, ob die Originalhinweise/Anleitung übersetzt werden</p> <p>NO: Sjekk at opprinnende brukerveiledning er oversatt</p> <p>BV: Kontrollera att den ursprungliga bruksanvisningen översätts</p> <p>DA: Tjekke om den originale brugsanvisning er oversat</p>	<p>FR: Vérifier que la notice originale est traduite</p> <p>DE: Überprüfen, ob die Originalhinweise/Anleitung übersetzt werden</p> <p>NO: Sjekk at opprinnende brukerveiledning er oversatt</p> <p>BV: Kontrollera att den ursprungliga bruksanvisningen översätts</p> <p>DA: Tjekke om den originale brugsanvisning er oversat</p>	<p>NO: Sjekk at opprinnende brukerveiledning er oversatt</p> <p>BV: Kontrollera att den ursprungliga bruksanvisningen översätts</p> <p>DA: Tjekke om den originale brugsanvisning er oversat</p>	<p>ES - Probación e ahoiti (Erklæring o tilsvarende tilsvarende 2006/42/EF, bilaga II, del A)</p> <p>1. Spoločnosť 2. Prohlasuje na vlastnú zodpovednosť, že stroj: Sekáčka so nastaviteľnou výškou na trávnu a) Typ / Model základného b) Materiál / Materiál výroby c) Sériové číslo d) Motor: spaľovací motor 3. Je v súlade s požiadavkami špecifikácie v prílohe A k smernici 2006/42/ES: a) Certifikácia typu b) Odkaz na harmonizované normy c) Měřená akustická výkonová moc d) Garantiovaná akustická výkonová moc e) Rozsah strihu f) Osoba autorizovaná na poskytnutie technického opisu g) Miesto a dátum</p>	<p>PL: Potwierdzenie niezgodności (originalna)</p> <p>ES - Declaración de conformidad (Directiva 2006/42/CE de los equipos, anexo II, parte A)</p> <p>1. La Empresa 2. Declara bajo su propia responsabilidad que el equipo: Cortacésped con altura de corte variable / cortacésped con altura de corte ajustable a) Tipo / Modelo Base b) Material / Material de fabricación c) Número de serie 3. Cumple con las especificaciones de las directivas: a) Examen CE de Tipo b) Referencia a las Normas armonizadas c) Nivel de potencia sonora medido d) Nivel de potencia sonora garantizado e) Amplitud de corte f) Persona autorizada a realizar el Manual Técnico g) Lugar y Fecha</p>

ES (Próval de la notificación)	ES (Próval de la notificación)	ES (Próval de la notificación)
<p>ES: Prueba de conformidad (Directiva 2006/42/CE, anexo II, parte A)</p> <p>1. La Empresa 2. Declara bajo su propia responsabilidad que la máquina: cortacésped con altura de corte variable / cortacésped con altura de corte ajustable a) Tipo / Modelo Base b) Materia / Materia de fabricación c) Número de serie d) Motor: motor gasolina 3. Est conforme a las especificaciones de las directivas: a) Examen CE de Tipo b) Referencia a las Normas armonizadas c) Nivel de potencia sonora medido d) Nivel de potencia sonora garantizado e) Amplitud de corte f) Persona autorizada a realizar el Manual Técnico g) Lugar y Fecha</p>	<p>ES: Próbning af samværetserklæring (Direktiv 2006/42/EF, Vedlegg II, del A)</p> <p>1. Firmaet 2. Erklærer på eget ansvar at maskinen: Slagmaskine / grassklipper a) Type (Model) b) Materiel / Byggekl. c) Seriennummer d) Motor: forbrenningsmotor 3. Oppføreren erklærer i tillegg: a) CE-tilsvarende b) Oppførers erklæring c) Harmoniserte standarder d) Målt effekt e) Garantierte snittebredde f) Målt lydtrykknivå g) Garantierte skjæregrenser h) Person som har fulført til å utarbeide tekniske dokumenter i) Sted og dato</p>	<p>ES: Probación e ahoiti (Erklæring o tilsvarende tilsvarende 2006/42/EF, bilaga II, del A)</p> <p>1. Spoločnosť 2. Prohlasuje na vlastnú zodpovednosť, že stroj: Sekáčka so nastaviteľnou výškou na trávnu a) Typ / Model základného b) Materiál / Materiál výroby c) Sériové číslo d) Motor: spaľovací motor 3. Je v súlade s požiadavkami špecifikácie v prílohe A k smernici 2006/42/ES: a) Certifikácia typu b) Odkaz na harmonizované normy c) Měřená akustická výkonová moc d) Garantiovaná akustická výkonová moc e) Rozsah strihu f) Osoba autorizovaná na poskytnutie technického opisu g) Miesto a dátum</p>
<p>NO: Sjekk at opprinnende brukerveiledning er oversatt</p> <p>BV: Kontrollera att den ursprungliga bruksanvisningen översätts</p> <p>DA: Tjekke om den originale brugsanvisning er oversat</p>	<p>NO: Sjekk at opprinnende brukerveiledning er oversatt</p> <p>BV: Kontrollera att den ursprungliga bruksanvisningen översätts</p> <p>DA: Tjekke om den originale brugsanvisning er oversat</p>	<p>NO: Sjekk at opprinnende brukerveiledning er oversatt</p> <p>BV: Kontrollera att den ursprungliga bruksanvisningen översätts</p> <p>DA: Tjekke om den originale brugsanvisning er oversat</p>
<p>FR: Vérifier que la notice originale est traduite</p> <p>DE: Überprüfen, ob die Originalhinweise/Anleitung übersetzt werden</p> <p>NO: Sjekk at opprinnende brukerveiledning er oversatt</p> <p>BV: Kontrollera att den ursprungliga bruksanvisningen översätts</p> <p>DA: Tjekke om den originale brugsanvisning er oversat</p>	<p>FR: Vérifier que la notice originale est traduite</p> <p>DE: Überprüfen, ob die Originalhinweise/Anleitung übersetzt werden</p> <p>NO: Sjekk at opprinnende brukerveiledning er oversatt</p> <p>BV: Kontrollera att den ursprungliga bruksanvisningen översätts</p> <p>DA: Tjekke om den originale brugsanvisning er oversat</p>	<p>FR: Vérifier que la notice originale est traduite</p> <p>DE: Überprüfen, ob die Originalhinweise/Anleitung übersetzt werden</p> <p>NO: Sjekk at opprinnende brukerveiledning er oversatt</p> <p>BV: Kontrollera att den ursprungliga bruksanvisningen översätts</p> <p>DA: Tjekke om den originale brugsanvisning er oversat</p>
<p>FR: Vérifier que la notice originale est traduite</p> <p>DE: Überprüfen, ob die Originalhinweise/Anleitung übersetzt werden</p> <p>NO: Sjekk at opprinnende brukerveiledning er oversatt</p> <p>BV: Kontrollera att den ursprungliga bruksanvisningen översätts</p> <p>DA: Tjekke om den originale brugsanvisning er oversat</p>	<p>FR: Vérifier que la notice originale est traduite</p> <p>DE: Überprüfen, ob die Originalhinweise/Anleitung übersetzt werden</p> <p>NO: Sjekk at opprinnende brukerveiledning er oversatt</p> <p>BV: Kontrollera att den ursprungliga bruksanvisningen översätts</p> <p>DA: Tjekke om den originale brugsanvisning er oversat</p>	<p>FR: Vérifier que la notice originale est traduite</p> <p>DE: Überprüfen, ob die Originalhinweise/Anleitung übersetzt werden</p> <p>NO: Sjekk at opprinnende brukerveiledning er oversatt</p> <p>BV: Kontrollera att den ursprungliga bruksanvisningen översätts</p> <p>DA: Tjekke om den originale brugsanvisning er oversat</p>
<p>FR: Vérifier que la notice originale est traduite</p> <p>DE: Überprüfen, ob die Originalhinweise/Anleitung übersetzt werden</p> <p>NO: Sjekk at opprinnende brukerveiledning er oversatt</p> <p>BV: Kontrollera att den ursprungliga bruksanvisningen översätts</p> <p>DA: Tjekke om den originale brugsanvisning er oversat</p>	<p>FR: Vérifier que la notice originale est traduite</p> <p>DE: Überprüfen, ob die Originalhinweise/Anleitung übersetzt werden</p> <p>NO: Sjekk at opprinnende brukerveiledning er oversatt</p> <p>BV: Kontrollera att den ursprungliga bruksanvisningen översätts</p> <p>DA: Tjekke om den originale brugsanvisning er oversat</p>	<p>FR: Vérifier que la notice originale est traduite</p> <p>DE: Überprüfen, ob die Originalhinweise/Anleitung übersetzt werden</p> <p>NO: Sjekk at opprinnende brukerveiledning er oversatt</p> <p>BV: Kontrollera att den ursprungliga bruksanvisningen översätts</p> <p>DA: Tjekke om den originale brugsanvisning er oversat</p>

IT • Il contenuto e le immagini del presente manuale d'uso sono stati realizzati per conto di STIGA S.p.A. e sono tutelati da diritto d'autore – E' vietata ogni riproduzione o alterazione anche parziale non autorizzata del documento.

BG • Съдържанието и изображенията в настоящото ръководство са извършени за STIGA S.p.A. и са защитени с авторски права – Забранява се всяко неотризирано възпроизвеждане или промяна, дори и частично на документа.

BS • Sadržaj i slike iz ovog korisničkog priručnika napravljeni su isključivo za STIGA S.p.A. i zaštićeni su autorskim pravima – zabranjena je svaka neovlašćena reprodukcija ili izmjena dokumenta, djelomično ili u potpunosti.

CS • Obsah a obrázky v tomto návodu k použití byly zpracovány jménem společnosti STIGA S.p.A. a jsou chráněny autorským právem – Reprodukce či nepovolené pozměňování tohoto dokumentu, a to i částečně, je zakázáno.

DA • Indhold og illustrationer i denne vejledning er blevet skabt på vegne af STIGA S.p.A. og er beskyttet af ophavsret – Enhver gengivelse eller ændring, også delvis, af dokumentet uden autorisation hertil er forbudt.

DE • Inhalt und Bilder dieser Bedienungsanleitung wurden im Namen von STIGA S.p.A. erstellt und sind urheberrechtlich geschützt – Jede nicht genehmigte Vervielfältigung oder Veränderung, auch auszugsweise, dieses Dokuments ist verboten.

EL • Το περιεχόμενο και οι εικόνες στο παρόν εγχειρίδιο χρήσης δημιουργήθηκαν για λογαριασμό της εταιρείας STIGA S.p.A. και προστατεύονται από πνευματικά δικαιώματα – Απαγορεύεται οποιαδήποτε αναπαραγωγή ή τροποποίηση, έστω και μερική, του εγγράφου χωρίς έγκριση.

EN • The content and images in this User Manual were produced expressly for STIGA S.p.A. and are protected by copyright – any unauthorised reproduction or modification to the document, either partially or in full, is prohibited.

ES • El contenido y las imágenes del presente manual de uso han sido creados por STIGA S.p.A. y están protegidos por los derechos de autor – Se prohíbe toda reproducción o modificación, incluso parcial, no autorizada del documento.

ET • Käesoleva kasutusjuhendi sisu ja kujutised on toodetud konkreetselt ettevõttele STIGA S.p.A. ja neile rakendub autorikaitseseadus – dokumendi igasugune osaline või täielik ilma loata reprodutseerimine või muutmine on keelatud.

FI • Tämän käyttöoppaan sisältö ja kuvat on valmistettu STIGA S.p.A. -yhtiön toimesta ja niitä suojaa tekijänoikeuslaki. – Asiakirjan kaikenlainen kopioiminen tai muuttaminen, osittainkin, on kielletty ilman erityistä lupaa.

FR • Le contenu et les images du présent manuel d'utilisation ont été réalisés pour le compte de STIGA S.p.A. et sont protégés par un droit d'auteur – Toute reproduction ou modification non autorisée, même partielle, du document, est interdite.

HR • Sadržaj i slike u ovom priručniku za uporabu izrađeni su za tvrtku STIGA S.p.A. te su obuhvaćeni autorskim pravima – Zabranjuje se neovlašćeno umnožavanje ili prilagodba, djelomična ili u cijelosti, ovog dokumenta.

HU • Ennek a használati útmutatónak a tartalma és a benne szereplő képek kizárólag a STIGA S.p.A. számára készültek és szerzői joggal védettek – tilos a dokumentum bármely részének vagy egészének engedély nélküli sokszorosítása és módosítása.

LT • Šio naudotojo vadovo turinys ir paveikslėliai skirti tik „STIGA S.p.A.“ ir yra saugomi autorių teisėmis – dokumentą atgaminti ar modifikuoti, visiškai arba iš dalies, yra draudžiama.

LV • Šis lietotāja rokasgrāmatas saturs un attēli ir veidoti tikai STIGA S.p.A. un ir aizsargāti ar autoritētibām. Jebkāda dokumenta vai tā daļas prettiesiska kopēšana vai pārveide ir stingri aizliegta.

MK • Содржината и сликите во Упатството за корисникот се подготвени исклучиво за STIGA S.p.A. и се заштитени со авторски права – забрането е секое делумно или целосно неовластено репродуцирање или измена на документот.

NL • De inhoud en de afbeeldingen van deze gebruikshandleiding werden gerealiseerd voor rekening van STIGA S.p.A. en zijn beschermd door het auteursrecht – Elke niet-geautoriseerde reproductie of wijziging, ook gedeeltelijke, van het document is verboden.

NO • Innholdet og bildene i denne brukerveiledningen er utført på oppdrag fra STIGA S.p.A. og er beskyttet ved opphavsrett – Enhver gjengivelse eller endring, selv kun delvis, er forbudt.

PL • Treść oraz ilustracje zawarte w niniejszej instrukcji obsługi powstały na zlecenie spółki STIGA S.p.A. i są chronione prawami autorskimi – Zabrania się wszelkiego kopiowania bądź modyfikowania, także częściowego, niniejszego dokumentu bez uzyskania stosownej zgody.

PT • As imagens e os conteúdos contidos no presente Manual do Utilizador foram expressamente criados para uso exclusivo da STIGA S.p.A., encontrando-se protegidos por direitos de autor. Qualquer tipo de reprodução ou alteração, parcial ou integral, não autorizadas deste Manual estão expressamente proibidas.

RO • Conținutul și imaginile din manualul de utilizare de față au fost realizate în numele STIGA S.p.A. și sunt protejate de drepturi de autor – Este interzisă orice reproducere sau modificare chiar și parțială neautorizată a documentului.

RU • Тесты и изображения, содержащиеся в настоящем руководстве, были созданы в интересах STIGA S.p.A. и защищены авторскими правами – Любое несанкционированное воспроизведение или изменение документа запрещено.

SK • Obsah a obrázky v tomto návode na používanie boli spracované menom spoločnosti STIGA S.p.A. a sú chránené autorským právom – Reprodukcie či nepovolené pozměňovanie tohto dokumentu, a to aj čiastočne, je zakázané.



SL • Vsebine in slike v tem uporabniškem priručniku so izdelane za podjetje STIGA S.p.A. in so zaščiten z avtorskimi pravicami – vsakršno nepooblaščenno razmnoževanje ali spreminjanje dokumenta, v celoti ali delno, je prepovedano.

SR • Sadržaj i slike ovog priručnika za upotrebu su napravljeni u ime STIGA S.p.A. i zaštićeni su autorskim pravima – Zabranjena je svaka potpuna ili delimična reprodukcija ili izmena dokumenta bez odobrenja.

SV • Innehållet och bilderna i denna användarhandbok har framställts för STIGA S.p.A. och skyddas av upphovsrätt – all form av reproduktion eller ändring, även partiell, som inte auktoriserats är förbjuden.

TR • Bu Kullanıcı Kilavuzundaki içerik ve resimler açıkça STIGA S.p.A. için üretilmiştir ve telif hakkı ile korunmaktadır – dokümanın izinsiz olarak tamamen ya da kısmen herhangi bir şekilde çoğaltılması ya da değiştirilmesi yasaktır.



.....	
Type:	 LWA dB
..... -s/n -Art.N	
	

STIGA SpA
Via del Lavoro, 6
31033 Castelfranco Veneto (TV) ITALY